

**IR-M17**                      Series

**INFRARED THICKNESS METER**

**Model: IR-M1700**

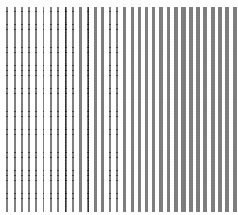

# **INSTRUCTIONS**

Always keep these instruction with the unit.

Please be sure to deliver these instructions with the unit to the end user.

**PREFACE** Requests and notices

Please read this instruction manual for using this Infrared thickness meter “IR-M1700 series” correctly and safely.

**Request to the operator of this instrument**

This instruction manual is necessary for maintenance, too.

Keep this instruction manual with the Infrared thickness meter.

If you have unclear points or need technical assistance, please contact your sales agent of CHINO Corporation.

<b>Note</b>	<ol style="list-style-type: none"> <li>1. The information in this manual is subject to change without notice and does not represent a commitment on the part of CHINO Corporation.</li> <li>2. No part of this manual may be reproduced or transmitted in any form or by any means, electronic or mechanical, including photocopying and recording, for any purpose other than the purchaser’s personal use without permission of CHINO Corporation.</li> <li>3. CHINO Corporation shall not be liable for any operation results.</li> </ol>
-------------	--

**FOR SAFE USE**

To use this unit correctly and safely, please keep the following contents safety measures for the operation this Infrared thickness meter “IR-M1700 series”

**Symbols in this instruction manual**

The symbols shown below are used depending on important degrees for using the “Infrared thickness meter “IR-M1700 series” safely and avoiding unexpected situations.



This warning mark is struck to the portions being subject to an electric shock accident. Turn off the power supply of the feed source without fail before starting wiring, maintenance, and repair.

Important degree	Symbols	Contents
1		This symbol is attached to a title for the sentence with <b>Warning</b>
2		For avoiding dangerous accidents(may cause death or serious injury) like as electrical shock, or troubles/damages of the Infrared thickness meter.
3		For avoiding injury or in physical damage to the Infrared thickness meter.
4		Information that we suggest to read carefully.
5		Information that you can use as a reference.

## CAUTIONS FOR SAFETY



Items	Explanations
<b>Power supply</b>	Make sure that the power voltage of this unit meets the feed power voltage without fail before feeding power to this unit.
<b>Protective grounding</b>	Perform the protective grounding without fail before turning on the power supply of this unit for the purpose of preventing an electric shock accident.
<b>Necessity of protective grounding</b>	Don't cut the internal or external protective grounding wire of this unit nor disconnect the wiring at the protective grounding terminal.
<b>A defect of protective functions</b>	Don't operate this unit, if the protective grounding, fuse, or other protective functions seem to be defective. Check the protective functions for defects before operating this unit.
<b>Use in a gaseous atmosphere</b>	Never operate this unit at a place where a combustible gas, an explosive gas or their vapors exist, otherwise a very dangerous accident will occur.
<b>Never touch the interior by hand</b>	This unit is internally provided with high-voltage circuits. Never touch the interior by hand when the voltage is applied to this unit.
<b>External connections</b>	Perform the protective grounding securely without fail before connecting this unit to a measuring object and/or an external control circuit.

# Contents

## 1. Introduction

- 1.1 General
- 1.2 Configuration

## 2. Model and accessories

- 2.1 Model
- 2.2 Accessories

## 3. Installation and connections

- 3.2 Mounting of air purge hood
- 3.3 Installation
- 3.4 Cautions on installation
- 3.5 Connections
- 3.6 Wiring of connection cables

## 4. Names and functions of component parts

- 4.1 Names and functions of component parts
- \*4.2 Setting and display part

## 5. Operation

- 5.1 Check before starting operation
- \*5.2 Setting of detector numbers
- \*5.3 Setting of calibration curve
- \*5.4 Setting of broken line approximation calibration curve
- \*5.5 Setting of operating conditions
- \*5.6 Calibration
- \*5.7 Setting of calibration curve numbers
- \*5.8 Correction of calibration curve

## 6. Preparation of calibration curves

- 6.1 Sampling
- 6.2 Sample measurement
- \*6.3 Preparation of calibration curves

## 7. Check and maintenance

- 7.1 Periodical check
- 7.2 Self-diagnostic function
- 7.3 Troubleshooting being excluded from self-diagnosis
- 7.4 Maintenance parts
- 7.5 RAM clear

## 8. Specifications

- 8.1 Detector
- 8.2 Accessories

### Caution

Read the items marked with  in the title without fail. These paragraphs comprise **Warning** items.

### Caution

Asterisked items ( \* ) are applicable to the specifications with keys and display only.

# CONTENTS

<b>1. Introduction</b> .....	<b>1</b>	<b>6. Operation</b> .....	<b>15</b>
1.1 General.....	1	6.1 Confirmation before operation.....	15
1.2 Configuration.....	1	6.2 Setting of detector unit number.....	15
<b>2. Model and accessories</b> .....	<b>2</b>	6.2.1 Setting of detector unit number (Except model for IR-M17□□N).....	15
2.1 Model.....	2	6.2.2 Setting of detector unit number (Only model for IR-M17□□N).....	15
2.1.1 Detector.....	2	6.3 Setting of calibration curve (Except model for IR-M17□□N).....	16
2.1.2 Connection cable: IR-WERT.....	2	6.3.1 Setting data.....	16
2.1.3 Air purge hood: IR-WEA.....	2	6.3.2 Setting method of calibration curve.....	17
2.1.4 Output checker plate: IR-WEB.....	2	6.4 Setting of knee point approximation calibration curve (Except IR-M17□□N)....	17
2.2 Accessories.....	2	6.4.1 Setting of knee point data.....	18
<b>3. Setting and Installations</b> .....	<b>3</b>	6.4.2 Knee point line setting data.....	18
3.1 Setting of dipswitches.....	3	6.4.3 Setting of calibration curve data for knee point line approximation.....	19
3.1.1 Setting of DIP switch 1.....	4	6.5 Setting of operating conditions (Except model for IR-M17□□N).....	20
3.1.2 Setting of DIP switch 2 (Model for IR-M17□□□N only).....	4	6.5.1 Setting data.....	20
3.2 Mounting of “Air purge hood” (Model: IR-WEA).....	5	6.5.2 Setting.....	21
3.2.1 Mounting to detector.....	5	6.6 Calibration(Except model for IR-M17□□N)...	22
3.2.2 Adjustment of hood length.....	5	6.7 Setting of calibration curve number (Except model for IR-M17□□N).....	23
3.2.3 Air purge.....	5	6.8 Correction of calibration curve (Except model for IR-M17□□N).....	23
3.2.4 For cooling the detector with air.....	5	<b>7. Creation of calibration curves</b> .....	<b>24</b>
3.3 Installation of detector unit.....	6	7.1 Creation of calibration curve (Except model for IR-M17□□N).....	24
3.3.1 External profile and mounting dimensions....	6	7.1.1 Computation of regression expression.....	25
3.4 Cautions on installation.....	7	7.1.2 Confirmation of regression expression.....	26
3.4.1 Vibrations and impacts:.....	7	<b>8. Correction function by sample   temperature from external input</b> ....	<b>27</b>
3.4.2 Induction:.....	7	8.1 Summary.....	27
3.4.3 Ambient temperature and humidity:.....	7	8.2 Model.....	27
3.4.4 Optical path:.....	7	8.3 Wiring of detector unit.....	27
3.4.5 Measuring place (For objects in sheet state such as paper).....	8	8.4 Setting of dipswitch (Ref to [3.1 Setting of dipswitches]).....	27
<b>4. Connections</b> .....	<b>9</b>	8.5 Setting of correction enabled/disabled by sample temperature.....	28
4.1 Layout of connection cable.....	9	8.5.1 Setting at the detector unit.....	28
4.2 Single-detector connections:.....	9	8.5.2 Setting at the setting display unit.....	28
4.3 Multi-detector connections.....	10	8.6 Setting of sample temperature scaling (Only 4 to 20mA DC).....	29
4.3.1 Connections through the relay box (Model: IR-WEE1 or IR-WEE2).....	10	8.6.1 Setting at the detector unit.....	29
4.3.2 Connections without any relay box.....	11	8.6.2 Setting at the setting display unit.....	29
<b>5. Names and Functions   of Component parts</b> .....	<b>12</b>	8.7 Setting of sample temperature.....	29
5.1 Names and functions of the Detector.....	12		
5.2 Setting display unit (Except model for IR-M1700N).....	14		

8.8 Setting of calibration curve data.....	30
8.9 Measurement.....	31
8.10 Display of sampler temperature Ts .....	31
8.10.1 Display at the detector unit .....	31
8.10.2 Display at the setting display unit.....	31
<b>9. Inspection and maintenance ▲.....</b>	<b>31</b>
9.1 Periodical inspection.....	31
9.2 Self-diagnosis function .....	32
9.3 Measures against troubles not included in self-diagnosis.....	33
9.4 Maintenance parts▲.....	34
9.4.1 List of maintenance parts .....	34
9.4.2 Replacement of light source lamp .....	34
9.4.3 Replacement of motor.....	35
9.4.4 Replacement of lithium battery .....	36
9.4.5 Replacement of power supply unit.....	37
9.5 RAM clear.....	37
9.5.1 RAM clear (Except model for IR-M17□□□N) .....	37
9.5.2 RAM clear (Only model for IR-M17□□□N).....	37
<b>10. Specifications and external dimensions .....</b>	<b>38</b>
10.1 Detector .....	38
10.1.1 Specifications of the detector.....	38
10.1.2 External dimensions of the detector.....	39
10.2 Power supply unit (conforming to CE) :Model IR-WEP.....	39
10.3 Connection cable: Model IR-WERT.....	39
10.4 Air purge hood: Model IR-WEA for Model IR-M1700 .....	40
10.5 Output checker plate: Model IR-WEB for Model IR-M1700 .....	40
10.6 Water cooling plate: IR-WEW .....	40
10.7 Mounting adapter: IR-WED.....	41
10.8 Air cooling box: IR-WEX .....	41
10.9 Relaying box: IR-WEE1, IR-WEE2 .....	41

# 1. Introduction

## 1.1 General

The infrared thickness meter IR-M1700 series is designed as a reflection system no-contact on-line thickness meter utilizing the infrared absorption of thickness, and it consists of the detector, setting display unit, and accessories.

The detector is provided with 99 built-in calibration curves to output linear analog signals according to the thickness. Since this instrument provides the keys display and communication functions, it can be used as a single unit or combined with a personal computer.

Max. 9 detectors can be connected with the setting display unit that can set various parameters of the detectors and indicate the moisture value. Accessories comprise the connection cables, air purge hood, output checker plate, etc. This instruction manual describes the detector and accessories.

For the setting display unit, refer to the separate instruction manual for setting display unit.

## 1.2 Configuration

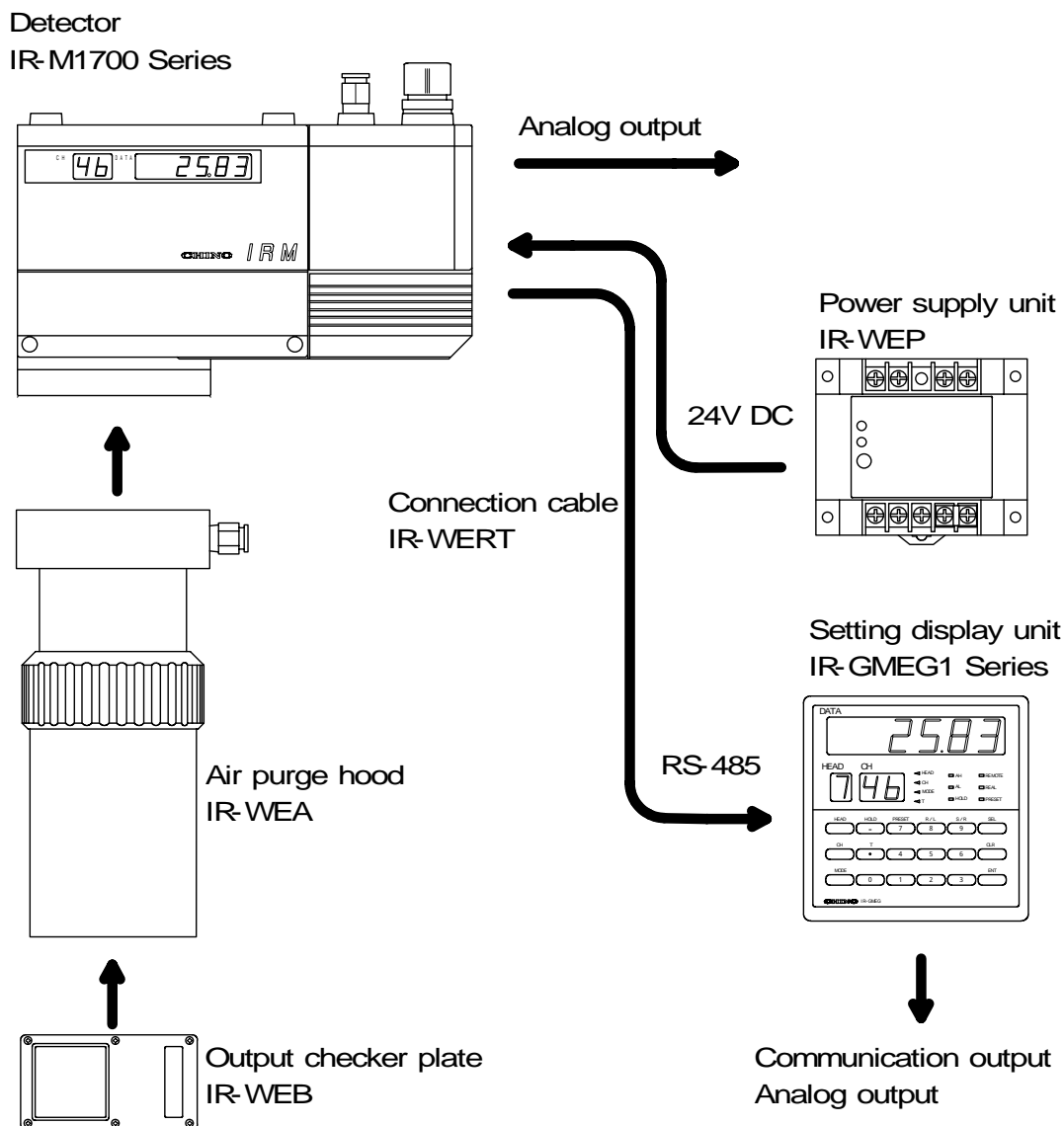

## 2. Model and accessories

### 2.1 Model

#### 2.1.1 Detector IR-M17

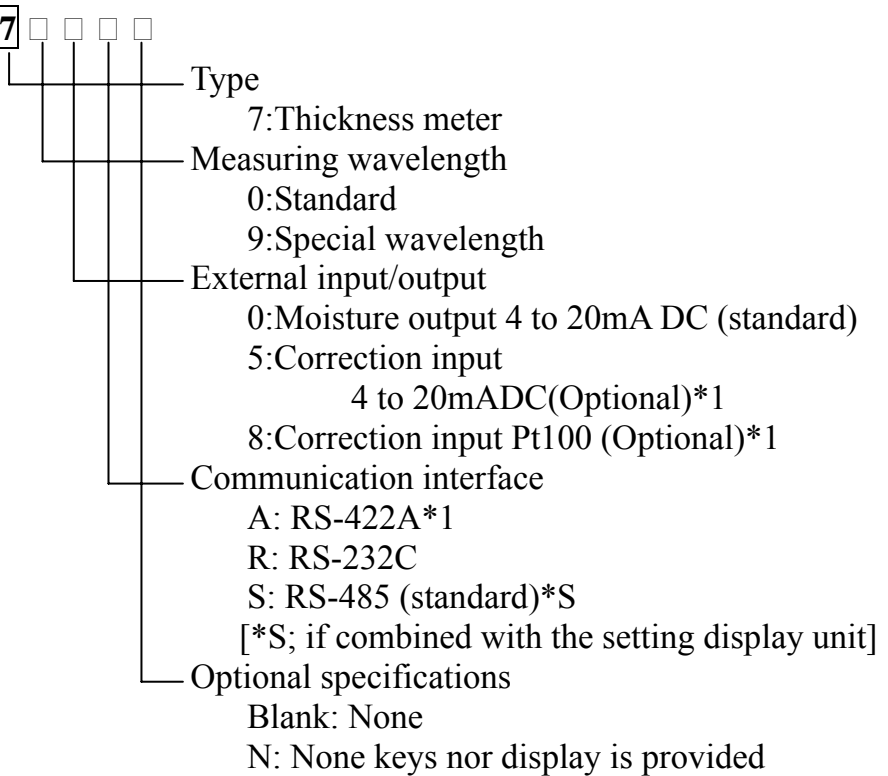

\*The following model only conforms to CE-marking. IR-M17□□SV  
 CE-marking specifications (Standards)  
 • EN55011 Group 1 Class A  
 • EN50082-2 (Industrial standards)  
 (Directives)  
 89/366/EEC, 92/31/EEC(amendment)  
 93/68/EEC (amendment)

\*1:Combination of “5” or “8” of optional external I/O and communications interface “A” is not possible.

#### 2.1.2 Connection cable : IR-WERT

#### 2.1.3 Air purge hood : IR-WEA

#### 2.1.4 Output checker plate: IR-WEB

### 2.2 Accessories

Article names	Quantity	Remarks
Power supply	1	Manufactured by OMRON
Fuse	2	Manufactured by Daito Tsushin Co.
L-type hexagonal wrench key	1	Diameter across flats 3
L-type hexagonal wrench key	1	Diameter across flats 4
Ferrite core	2	Attached to CE-marking conformance product only
Instruction manual	1	This manual
Instruction manual for communication	1	Attached to IR-M17□□ <span style="border: 1px solid black; padding: 2px;">R/A</span> □only



### 3. Setting and Installations ⚠

#### 3.1 Setting of dipswitches

Set the internal dipswitches before installation of the detector unit.

- 1) Open a door, remove 4 screws for fixing a setting display part and then remove the setting display part.
- 2) The setting display part is connected to the interior through cables. Lift the setting display part with due care so as not to damage the cable and disconnect the connector for the setting display part at the position shown in the figure.
- 3) Set the dipswitches according to the working conditions.

**Warning** Turn off the power supply before removing the setting display part.

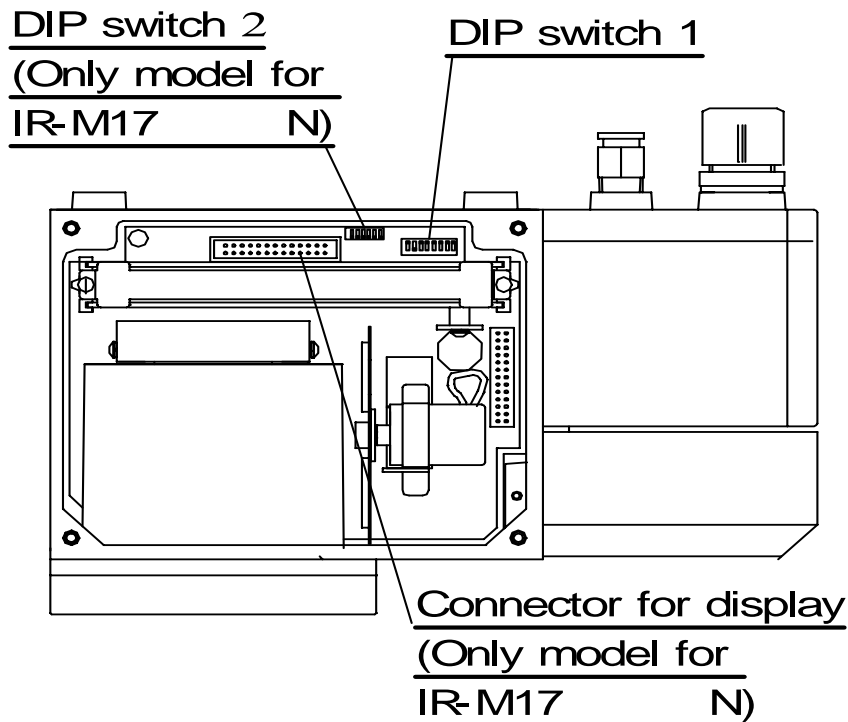
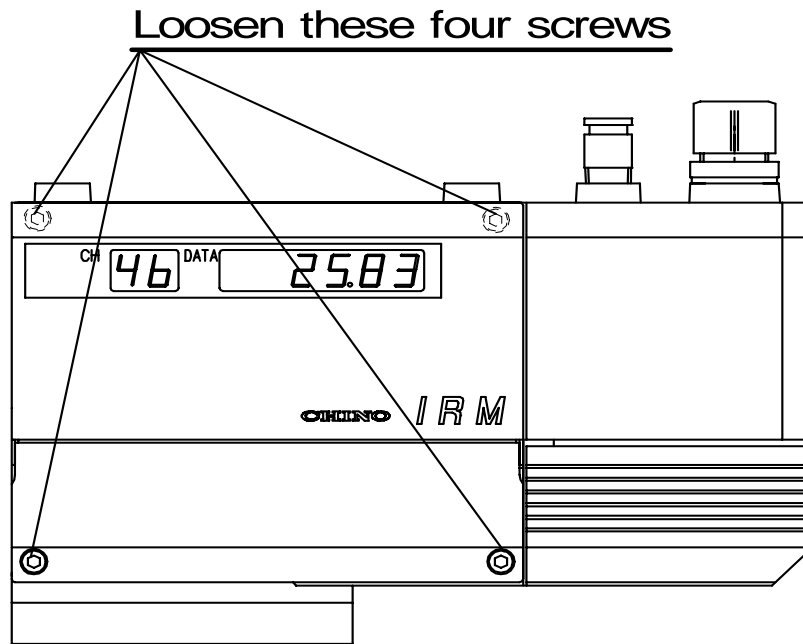

### 3. Setting and Installations

#### 3.1.1 Setting of DIP switch 1

DIP switch No	Function	SW		Defaults
		OFF	ON	
1	Measurement/Calibration mode	Measurement mode	Calibration mode	OFF (Don't change.)
2	Mathematical operation format	Logarithm operation	Ratio operation	ON (Don't change.)
3	No.2 calibration enable/disable	Disable	Enable	OFF
4	Connection destination	Setting display unit	PC	OFF : IR-M17□□S ON : IR-M17□□R IR-M17□□A
5	Key/display enable/disable	Enable	Disable	OFF: IR-M17□□□ ON : IR-M17□□□N
6	Not used			OFF
7	Correction input enable/disable	Disable	Enable	OFF
8	Correction input	4 to 20mADC	Pt100	OFF

#### 3.1.2 Setting of DIP switch 2 (Model for IR-M17□□□N only)

Detector No.	DIP switch No.			
	1	2	3	4
1				
2				○
3			○	
4			○	○
5		○		
6		○		○
7		○	○	
8		○	○	○
9	○			
RAM clear	○	○	○	○

Communication Speed (bps)	DIP switch No.	
	5	6
2400		
4800		○
9600	○	
19200	○	○

○ : ON

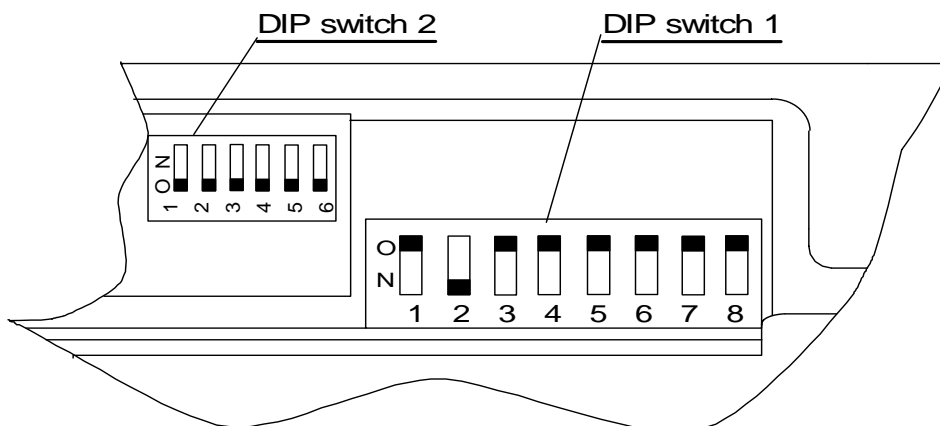

### 3. Setting and Installations

#### 3.2 Mounting of "Air purge hood"(Model: IR-WEA)

The air purge hood is used for shielding the light when electric lamp, flames, direct sunlight, or other disturbance light directly radiate on to the measuring surface. And the air purge hood is used for securing the optical path by air purge when water drops, dust particles, smoke, steam, etc. exist between the detector and the measuring surface. The hood length is variable.

##### 3.2.1 Mounting to detector

Position four hexagon socket head bolts of the air purge hood to the screw holes of "Air purge hood" mounting flange of the detector, and fix the air purge hood by fastening these bolts with a hexagonal wrench (diameter across flats 4).

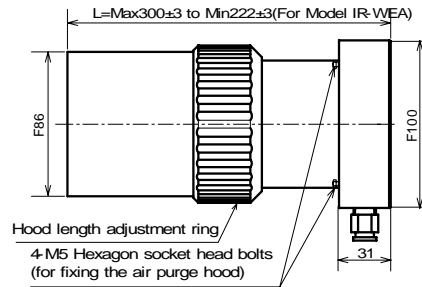

##### 3.2.2 Adjustment of hood length

Adjust the hood length after loosening the hood length adjusting ring counterclockwise, and fix the hood by fastening the hood length adjusting ring clockwise.

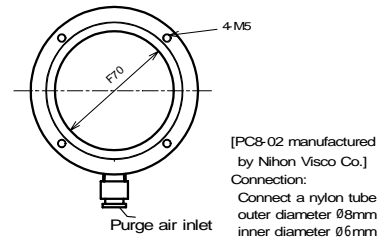

##### 3.2.3 Air purge

For air purge, feed a dry air excluding oil, dust, etc., through the purge air inlet. Connect a nylon tube of 8mm in outer diameter and 6mm in inner diameter.

- (The tube connection port is PC8-02 manufactured by Nihon Pisco Co.)
- Purge air flow: 50 to 200Nl/min
- Purge air pressure: Lower than 200kPa (2kgf/cm<sup>2</sup>)

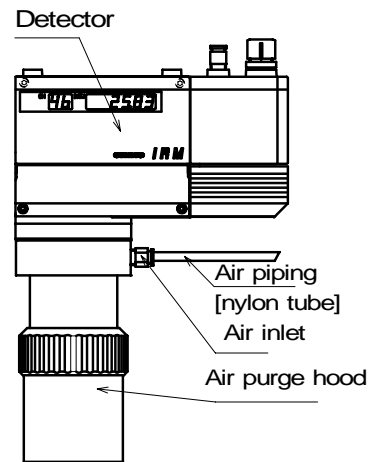

##### 3.2.4 For cooling the detector with air

When feeding the air after cooling the detector as a purge air, connect the air outlet and purge air inlet of the detector with a tube as shown in the figure. The recommendable air flow is about 50Nl/min.

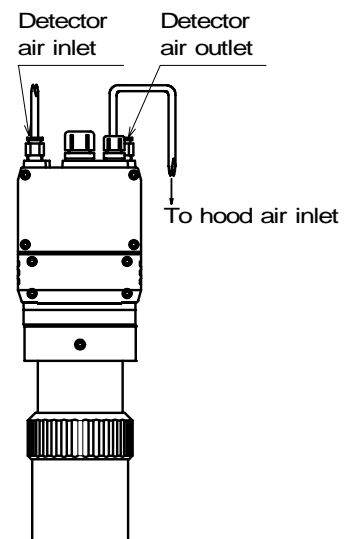

#### Caution

Cool down the detector with air as much as possible for enhancing the reliability of the detector. Cool it down with air without fail when the ambient temperature exceeds 45°C

### 3. Setting and Installations !

#### 3.3 Installation of detector unit

Four unit mounting screw holes (M8, 11mm in depth) are provided on the upper face of the detector. Fix the detector by a mounting plate with four M8 bolts. The external profile and mounting dimensions are as shown in the following figure.

- (1) For model IR-M1700 mount the detector so that the distance from the measuring surface becomes 300mm. (Mountable over a range from 200 to 400mm)
- (2) Since the visual light is radiated to the measuring surface, the measuring position can be confirmed.
- (3) Prepare the mounting plate according to the conditions at the mounting place. For the outer profile of the mounting plate, take the wiring space, etc. into account.

#### 3.3.1 External profile and mounting dimensions

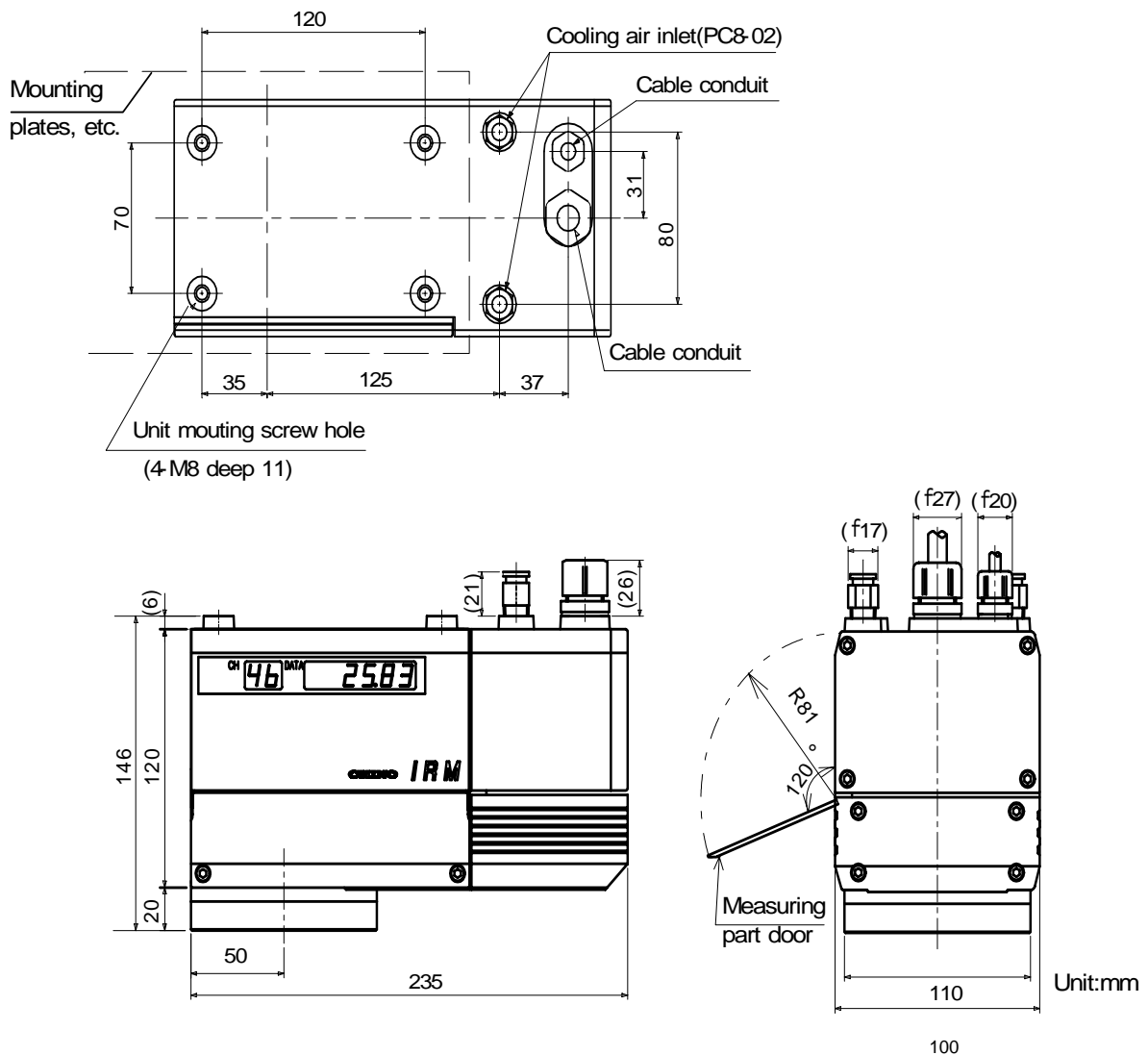

### 3. Setting and Installations



#### [Measuring distance/measuring area]

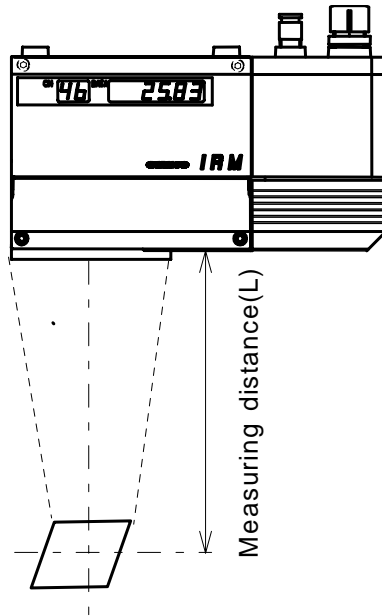

#### [For model IR-M1700series]

##### [Standard type]

Measuring distance (mm)	Measuring area (mm)
200	□30
300	□50
400	□70

##### [Small-diameter type]

Measuring distance (mm)	Measuring area (mm)
200	□30
300	□30
400	□40

### 3.4 Cautions on installation

#### 3.4.1 Vibrations and impacts:

Mount the detector at a place where is free of any noticeable vibrations or impacts. If it is used at a place subjected to vibrations and impacts due to unavoidable circumstances, separate the mounting plate from the vibration source or spread a shock-absorbing rubber sheet between the detector and the mounting plate for preventing vibrations.

#### 3.4.2 Induction:

The detector is designed by taking the induction resistance into account. However, separate it from the induction heating oscillator and power line as far as possible.

#### 3.4.3 Ambient temperature and humidity:

The ideal ambient temperature of the detector is 10 to 30°C. If the detector is used at a temperature higher than 45°C, cool it down by means of air.

If the detector is used at a temperature lower than 10°C, be careful with dew condensation on the cover glass face. Steam may cause the dew condensation on the cover glass face due to a change of the temperature under a very wet condition to resultantly cause a measuring error.

#### 3.4.4 Optical path:

Select a place where none of water drops, dust particles, smoke, steam, etc. enters between the detector and the measuring surface.

If these substances cannot be prevented due to unavoidable circumstances and their influences are not negligible, purge them with a compressed air or other remedial measure is necessary.

Out of the external light to the measuring surface, the light whose intensity does not change momentarily like the natural light does not act as the disturbance to the measurement. However, the light like an electric bulb, a flame, etc. acts as the disturbance. The intense light like the direct sunlight acts as the disturbance. In such a case, shield the disturbance light to prevent it from being radiated to the measuring surface directly.

### 3. Setting and Installations



#### 3.4.5 Measuring place (For objects in sheet state such as paper:

Tilt the detector by  $15^\circ$  from the vertical face as illustrated right.

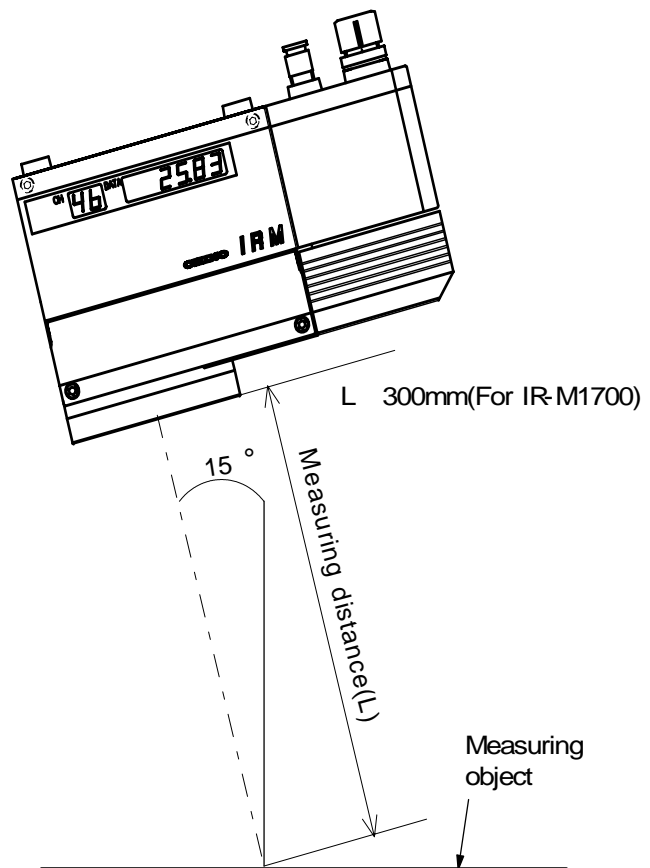

# 4. Connections ⚠

## 4.1 Layout of connection cable

For connection of cables, be careful of the following points.

- Separate the cables from induction heating oscillator and power lines.
- Keep the cables free of deposit of water, oil, etc.
- Don't bend the cables extremely or apply any excessive force to them.
- For permanent layout, protect the cables with conduits, etc.

## 4.2 Single-detector connections:

The internal terminal board is accessible by removing the power supply cover of the detector. Lead in cables through the upper cable lead-in port, and connect them to individual terminals. Lead in the exclusive cable IR-WERT through the large lead-in port.

**Warning**

For preventing electric shock, make sure to turn the power supply off before wiring.

**Caution**

Use a cable conforming to the applicable outer diameter ( $\phi 4.5$  to  $\phi 6.5$ mm) of the small cable inlet; otherwise waterproofing of the detector unit may deteriorate. Tighten the nut at the cable inlet securely after connections.

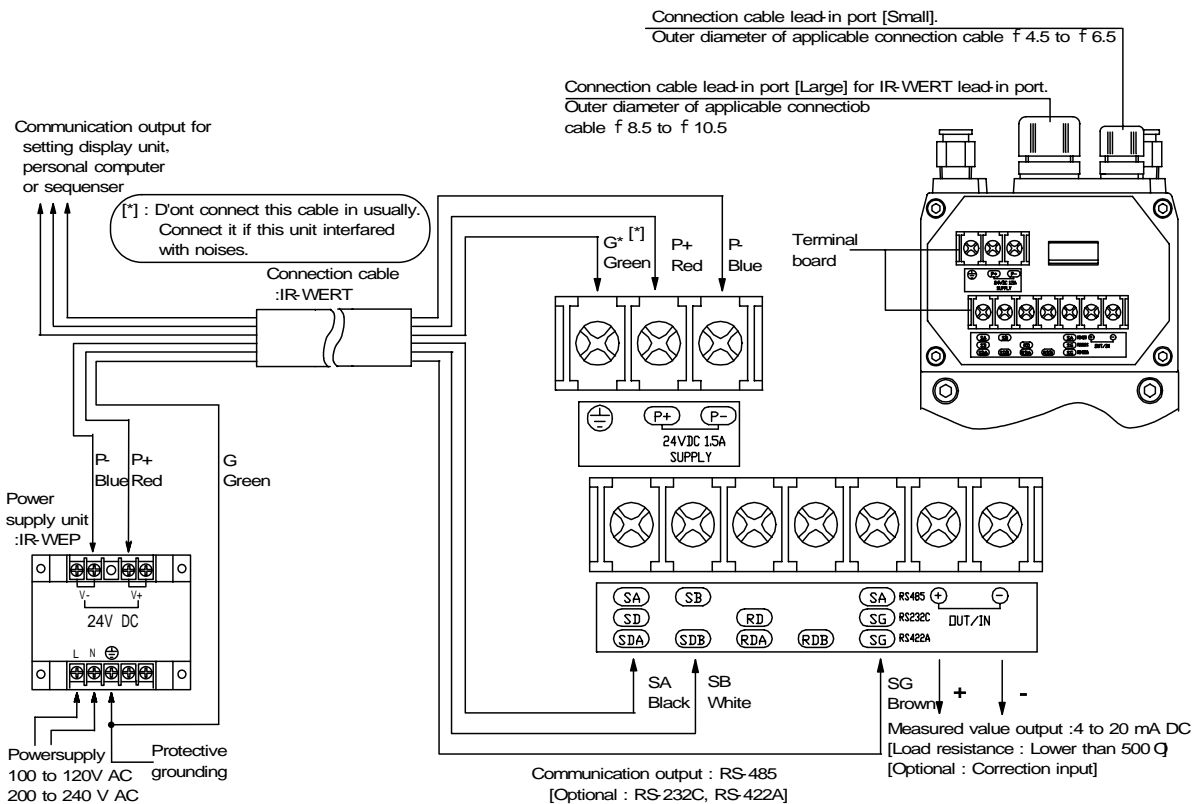

## 4. Connections ⚠

### 4.3 Multi-detector connections

By using the setting display unit, you can connect the detector unit up to 9 sets.  
 Two wiring methods are available. One is wiring through a relay box (IR-WEE□) and the other is without the relay box (IR-WEE□).

**Caution**

For both wiring methods, before connecting with the setting display unit or before turning on the power supply of the setting display unit, number setting to the detector units is required. For the number setting, be careful not to overlap any detector unit number of each detector unit. Refer to [6.2 Setting of detector unit number] for the details.

#### 4.3.1 Connections through the relay box (Model: IR-WEE1 or IR-WEE2)

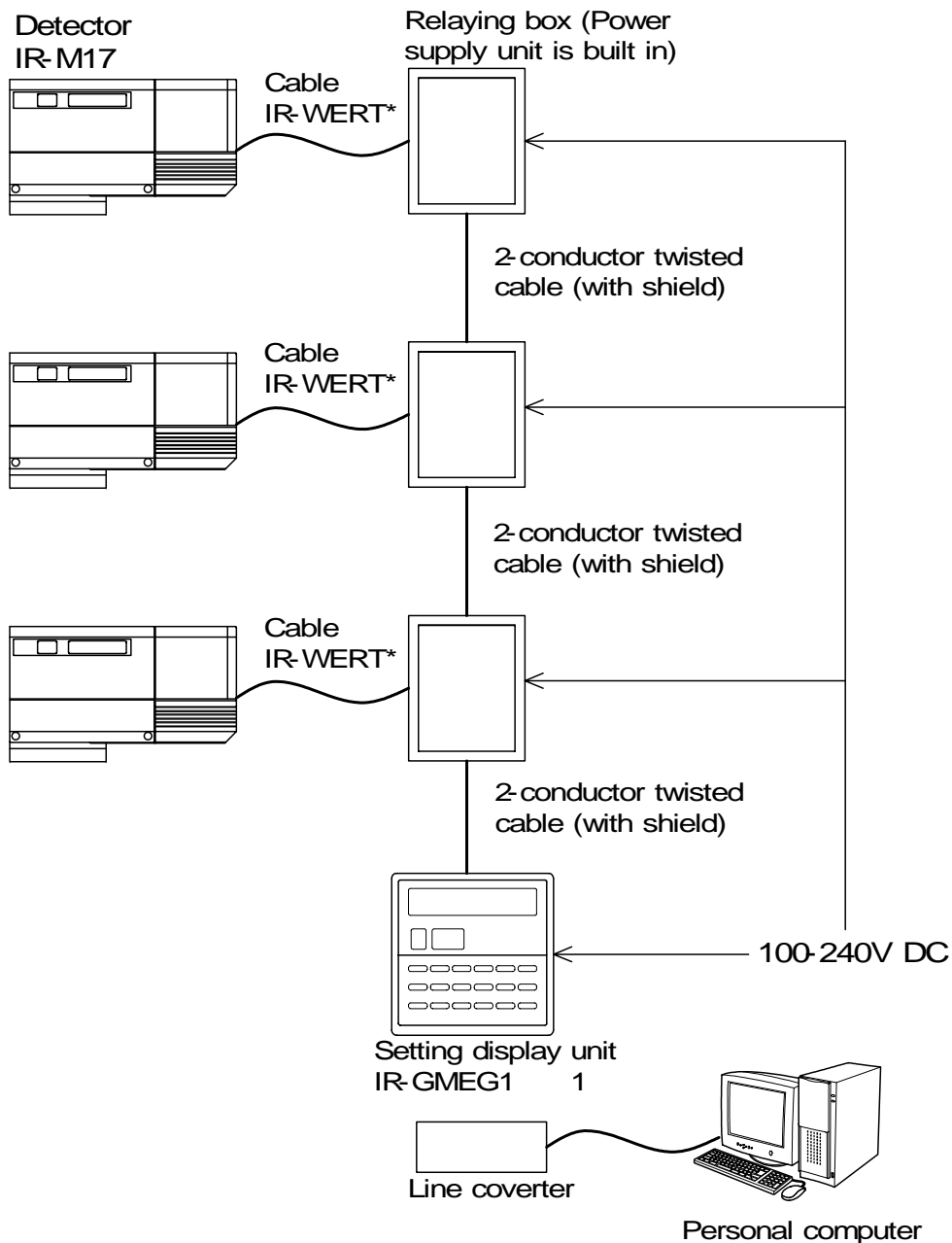

**Caution**

1. Shorten the length of exclusive cable (IR-WERT \* mark) as much as possible.
2. For wiring to the relay box, refer to “Instruction manual of relay box”.



# 4. Connections ⚠

## 4.3.2 Connections without any relay box

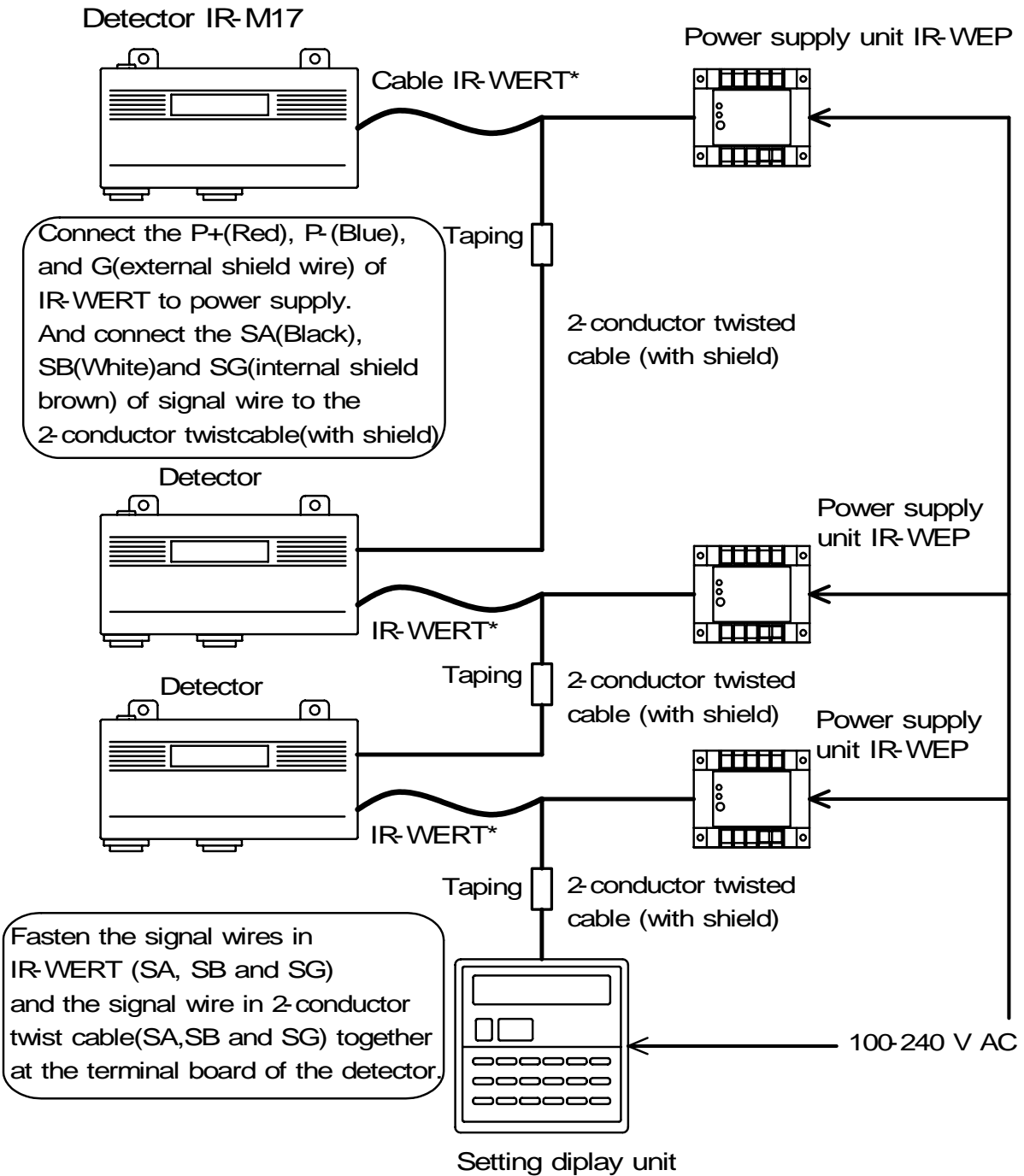

## 5. Names and Functions of Component parts

### 5.1 Names and functions of the Detector

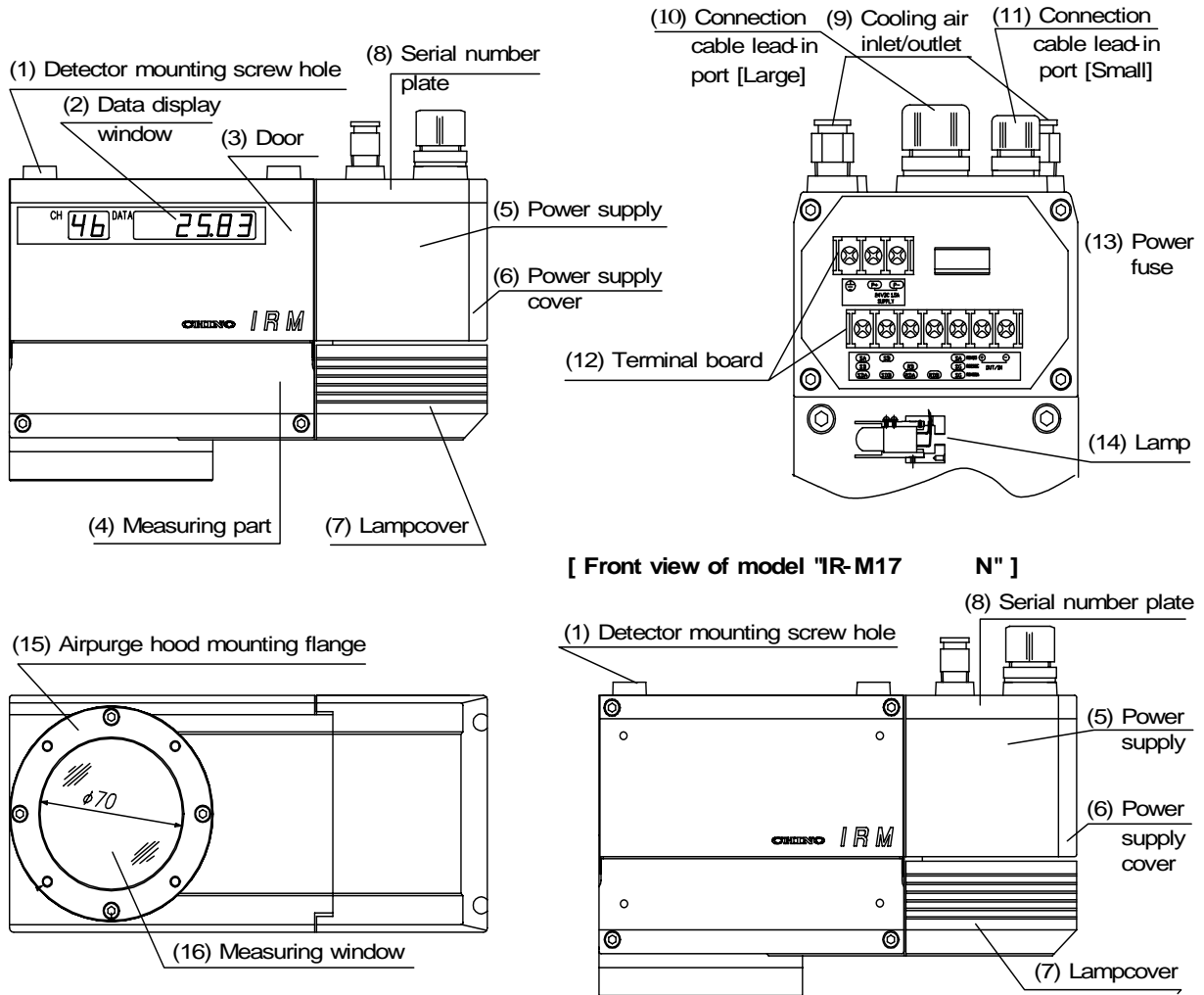

**(1) Detector mounting screw hole:**

Four M8 screw hole (11mm in depth) for fixing the detector to the mounting plate, etc.

**(2) Data display window (Except model for IR-M17□□□N):**

Displays the calibration curve numbers and measured values.

**(3) Door (Except model for IR-M17□□□N):**

By opening this setting display door, setting key switches are accessible. Since this door is opened or closed by a magnet system, and can be opened by pulling its upper part downward.

**(4) Measuring part:**

The optical system, detection element, and electric circuits are assembled.

**(5) Power supply:**

Terminal board for wiring, power fuse, power supply unit and output part are built in.

**(6) Power supply cover:**

This cover is fixed with four M4 hexagon socket head bolts, and remove in connections.

## 5. Names and Functions of Component parts

### 5.1 Names and functions of the Detector

**(7) Lamp cover:**

This cover is fixed with four M4 hexagon socket head bolts, and lamp is located inside.

**(8) Serial number plate:**

This detector's serial number plate is mounted at the upper part.

**(9) Cooling air inlet/outlet:**

This air inlet/output is used for cooling the power supply with air. Connect a nylon tube of 8mm  $\phi$  in outer diameter and 6mm  $\phi$  in inner diameter to this air inlet/output. The tube connection joint is PC8-02 manufactured by Nihon PISCO Co. Use a dry cooling air excluding oil, dust, and other foreign substances.

Recommendable air flow:

Approx. 50Nl/min

Maximum air pressure:

Lower than 200kPa (2kgf/cm<sup>2</sup>)

**(10) Connection cable lead-in port (large):**

The applicable connection cable to this connection cable lead-in port is 8.5mm  $\phi$  to 10.5mm  $\phi$  in outer diameter. Lead in exclusive cable IR-WERT through this port.

**(11) Connection cable lead-in port (small):**

The applicable connection cable to this connection cable lead-in port is 4.5mm  $\phi$  to 6.5mm  $\phi$  in outer diameter.

**(12) Terminal board:**

This internal terminal board is accessible by opening the power supply cover. For wiring of connection cables, and the terminal screw size is M4.

**(13) Power fuse:**

A 2A insertion type fuse of time-lag fusion type is mounted to the fuse holder.

**Warning**

Make sure to turn off the power supply before replacement of power fuse.

**(14) Lamp:**

Lamp for the infrared thickness meter.

**(15) Air purge hood mounting flange:**

This flange is provided with four M5 screw holes.

**(16) Measuring window:**

Measuring window for light projection and reception.

## 5. Names and Functions of Component parts

### 5.2 Setting display unit (Except model for IR-M1700N):

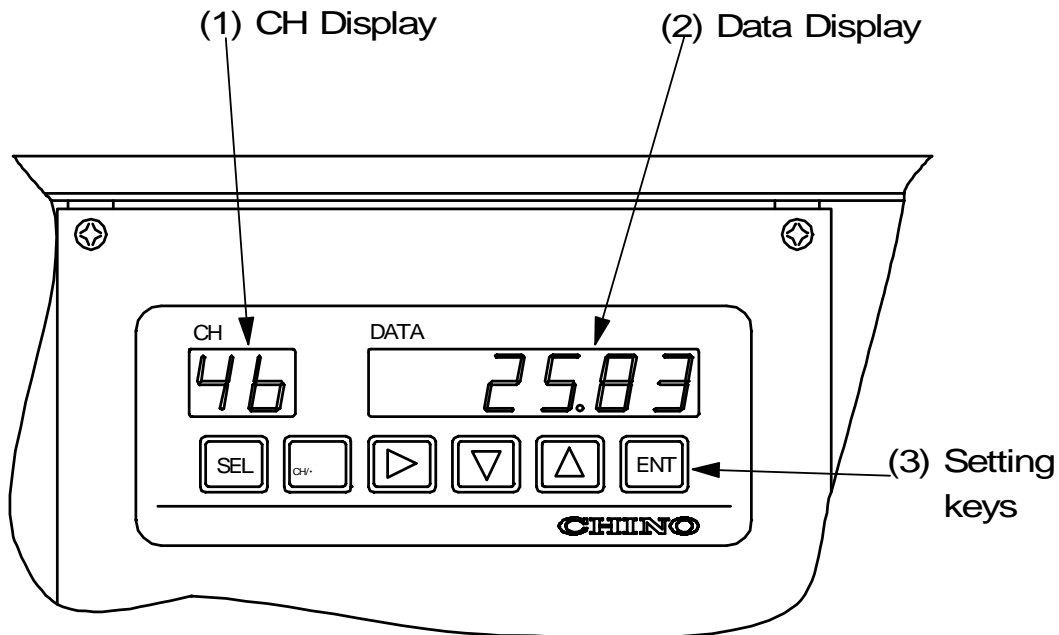



(1) **CH display:** Displays a calibration curve number in measurement mode and a parameter item in setting mode.

(2) **Data display** Displays a measured value in the measurement mode and a parameter in the setting mode.

#### (3) Setting keys

 : For entering into the setting mode and switching a setting screen.

 : For setting a calibration curve number in the measurement mode and for entering a decimal point in the setting mode. When the key is pressed again, the decimal point disappears.

 : For entering into a parameter setting in the setting mode and changing the digit of the parameter.

 : For changing the parameter in the setting mode.

 : For changing the parameter in the setting mode.

 : For storing the parameter in the setting mode.

## 6. Operation

### 6.1 Confirmation before operation

Check the following two points before turning on the power supply.

- 1) Have the dipswitches been set? (Refer to [3.1 Setting of dipswitches])
- 2) Is wiring correct? (Refer to [4. Connection])

### 6.2 Setting of detector unit number

#### 6.2.1 Setting of detector unit number (Except model for IR-M17□□N)

Detector unit numbers are for identifying each detector unit when multiple detector units are connected to the setting display unit. (Refer to [4.3 Multi-detector connection]). Set a detector unit number before connecting the setting display unit.

#### Reference

The default number of the detector unit is "1".  
For using it with a number other than 1, set the detector unit number by following order.

- 1) Enter into the operation condition setting mode by pressing **SEL** key and **ENT** key simultaneously to set CH display "t" for 2 seconds.
- 2) Press **SEL** key 4 times to set CH display to "Hn".
- 3) By pressing **▶** key, the numeric blinks for entering a detector unit number.
- 4) Change the numeric by key or key.
  - When **▲** key is pressed, the numeric is increased.
  - When **▼** key is pressed, the numeric is decreased.
  - When **▶** key is pressed, the blinking digit shifts.
- 5) When **ENT** key is pressed, the numeric stops blinking and the detector number is stored.
- 6) Return to the measurement mode by pressing **SEL** key for 2 seconds.

CH	DATA
t	0.0

CH	DATA
Hn	1

↑  
Detector No

#### Reference

The following setting can be done from "Setting display unit" (Model: IR-GMEG).  
Refer to the "Instructions for setting display unit".

#### 6.2.2 Setting of detector unit number (Only model for IR-M17□□N)

In case of using "IR-M17□□N", set the detector unit number by referring to [3.1.2 Setting of DIP switch 2 (Model for IR-M17□□N only)]

## 6. Operation

### 6.3 Setting of calibration curve (Except model for IR-M17□□N)

#### Reference

When using models except for “IR-M17□□N”, the following setting can be done from “Detector unit ” or “Setting display unit”.  
Set from “Setting display unit”, if using “IR-M17□□N”.

The output characteristic of infrared thickness meter depends upon measuring objects. It may also change according to the process conditions and sample thickness measuring conditions. Therefore, it is necessary for accurate thickness measurements to perform a sample test of the object and obtain the correlation (This is called as calibration curve.) between the thickness value ( $\mu\text{m}$ ) obtained by a drying method or other measuring methods and the absorbance “x” measured by the thickness meter.

#### Reference

This paragraph describes the setting method for calibration curve data, assuming that calibration curves have been already created.  
When the calibration curves have not been created yet, refer to [7.Creation of calibration curves].

#### 6.3.1 Setting data

The followings are the setting data of calibration curve.

Data name	Display	Setting range	Default value	Remarks
(1) Calibration curve No.	CH	1 to 99	1	
(2) Polynomial coefficient $a_0$	A0	0 to $\pm 9999.9$	0.0000	Effective numeric: 5 digits
(2) Polynomial coefficient $a_1$	A1	0 to $\pm 9999.9$	0.0000	Effective numeric: 5 digits
(2) Polynomial coefficient $a_2$	A2	0 to $\pm 9999.9$	0.0000	Effective numeric: 5 digits
(2) Polynomial coefficient $a_3$	A3	0 to $\pm 9999.9$	0.0000	Effective numeric: 5 digits
(3) Correction expression coefficient $b_0$	B0	0 to $\pm 9999.9$	0.0000	Effective numeric: 5 digits
(3) Correction expression coefficient $b_1$	B1	0 to $\pm 9999.9$	1.0000	Effective numeric: 5 digits
(4) Output low limit moisture	Hi	0 to 9999.9	0.00	Decimal digit depends on specification.
(4) Output high limit moisture	Hi	0 to 9999.9	100.00	Decimal digit depends on specification.
(5) Low limit alarm moisture	AL	0 to 9999.9	0.00	Decimal digit depends on specification.
(5) High limit alarm moisture	AH	0 to 9999.9	100.00	Decimal digit depends on specification.
(6) Preset moisture	PS	0 to 9999.9	0.00	Decimal digit depends on specification.

#### (1) Calibration curve number

An optional number from 1 to 99 can be designated as the calibration curve. It is designated sequentially from “1” usually.

#### (2) Polynomial coefficient “ $a_0$ to $a_3$ ”

Assume that the calibration curve is represented by third-degree or lower-degree polynomial as shown below.

$$y = a_3x^3 + a_2x^2 + a_1x + a_0$$

where, “y” is the thickness value ( $\mu\text{m}$ ) and “x” is the absorbance (“CH0” data of this thickness meter).

#### (3) Correction expression coefficient “ $b_0$ to $b_1$ ”

These coefficients are provided for primary expression correction (zero and span correction) with reference to thickness value “y”. Assuming that the thickness value after correction be “Y”, we obtain.  $y = b_1y + b_0$

## 6. Operation

### (4) Output low limit moisture, output high limit thickness

These thickness values are specified as the output low limit and output high limit on the analog output scaling. These values are scaled to be 4mA at the output low limit thickness and 20mA at the output high limit thickness.

### (5) Low limit alarm thickness, high limit alarm thickness

The low limit alarm activates when a measured value is lower than the low limit alarm thickness, while the high limit alarm activates when a measured value is higher than the high limit alarm thickness. Since the detector unit does not provide any alarm output function, the setting display unit is required when an alarm output is necessary.

### (6) Preset thickness

By turning on the preset output by key operations or through communications, the thickness value being set as preset thickness is displayed and output, regardless of the measured value.

### 6.3.2 Setting method of calibration curve

1) Press **SEL** key for 2 seconds to enter into the calibration curve data-setting mode.

2) By pressing **▷**key, a numeric blinks for entering a calibration curve number.

3) Change the numeric by **△**key, **▽**key or **▷**key.

When **△**key is pressed, the numeric is increased.

When **▽**key is pressed, the numeric is decreased.

When **▷**key is pressed, the blinking digit shifts.

4) When **ENT** key is pressed, the numeric stops blinking and the calibration curve number is stored.

5) Press **SEL** key to enter into the setting mode for polynomial coefficient  $a_0$ .

6) Enter into a numeric setting mode by pressing **▷**key. Change the numeric by **△**key or **▽**key and store it by pressing **ENT** key.

For entering a decimal point, press **CH/·** key at the blinking digit.

7) Press **SEL** key to enter into the next data setting mode.

8) Repeat the above procedure to set all data.

9) After the above setting procedure is completed, return to the measurement mode by pressing **SEL** key for 2 seconds. The automatic return is made if no key is pressed for one minute.

CH	CH	DATA	0
----	----	------	---

CH	CH	DATA	0
	↑		↑
	Detector No		Blinking

CH	A 0	DATA	0 . 0 0 0 0
	↑		↑
Setting data	name	Setting data	displayed
displayed		displayed	

### 6.4 Setting of knee point approximation calibration curve (Except IR-M17□□N)

#### Reference

When using models except for “IR-M17□□N”, the following setting can be done from “Detector unit ” or "Setting display unit”.  
Set from "Setting display unit”, if using “IR-M17□□N”.

When a calibration curve is obtained in a graph but it cannot be expressed in third-degree or lower-degree polynomial, the calibration curve can be created by knee point line approximation.

## 6. Operation

### 6.4.1 Setting of knee point data

- 1) Supposing that the calibration curve graph is as shown in the following figure.
- 2) Divide the calibration curve graph appropriately and express it with knee point line approximation.
- 3) In this case, the first junction point and the last junction point should sufficiently include the measuring range. You can plot up to 20 junction points including the first junction point and the last junction point. Determine intermediate junction points appropriately according to the approximation accuracy.
- 4) Supposing that the junction point data obtained by the above are as shown below.

First junction point      $d_1: (x_1, y_1)$   
     $d_2: (x_2, y_2)$   
 Last junction point      $d_n: (x_n, y_n)$   
     $\uparrow$   
    Data number

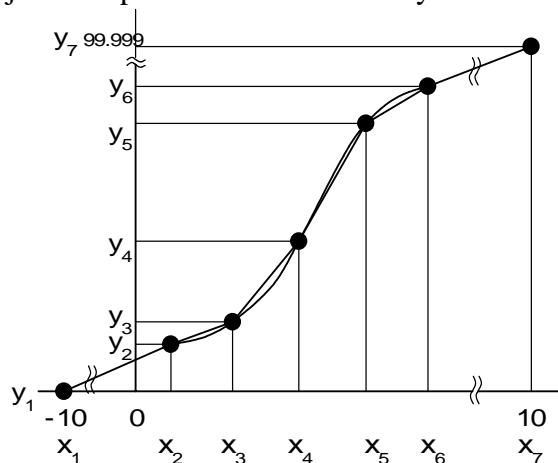

### 6.4.2 Knee point line setting data:

The following data is necessary for the creation of the calibration curve by knee point line approximation.

Data name	Display	Setting range	Default	Remarks
(1) Calibration curve No	CH	1 to 99	1	
(2) Data count	N	3 to 20	3	
(3) Data number	Dn	1 to 20	1	
(3) Sample data $x_n$	Hn	0 to $\pm 9999.9$	0.0000	Valid number 5 digits
(3) Sample data $y_n$	yn	0 to $\pm 9999.9$	0.0000	Valid number 5 digits
(4) Regression/Knee point line	Pb	1 to 4	1	1 to 3: Polynomial expression degree (Regression operation) 4: Knee point line approximation
(5) Standard deviation	Sd	0 to 999.99	0.0000	Setting not required in knee point line approximation

**(1) Calibration curve number:**

Calibration curve number can be specified in optional numbers from 1 to 99 but usually it is specified in order from 1.

**(2) Data count:** It is the number of knee point data and the maximum is 20 points.

**(3) Data number, sample data  $x_n$ , sample data  $y_n$ :**

Enter the knee point data obtained in [6.4.1 Setting of knee point data].

**(4) Regression/knee point line:**

With entering 1, 2 or 3, the polynomial expression with that degree can be obtained according to the above sample data by regression operation.

When 4 is entered, knee point line approximation is obtained.

**(5) Standard deviation:**

When the regression operation is specified, standard deviation is displayed. This setting is not required in knee point line approximation.



## 6. Operation

### 6.4.3 Setting of calibration curve data for knee point line approximation

#### (1) Setting of calibration curve number

- 1) Press **SEL** key and **CH/.** key simultaneously for 2 seconds to enter into the sample data setting mode.
- 2) By pressing **CH/.** key, a numeric blinks for entering a calibration curve number.
- 3) Change the numeric by **Δ** key, **▽** key or **▶** key.  
When **Δ** key is pressed, the numeric is increased.  
When **▽** key is pressed, the numeric is decreased.  
When **▶** key is pressed, the blinking digit shifts.
- 4) When **ENT** key is pressed, the numeric stops blinking and the calibration curve number is stored.

CH	CH	DATA	0
----	----	------	---

CH	CH	DATA	01
----	----	------	----

↑
↑  
 Detector No                      Blinking

CH	n	DATA	4
----	---	------	---

↑
↑  
 Setting data name                      Setting data displayed

#### (2) Setting of data count

- 1) Press **SEL** key to enter into the data count setting mode.
- 2) Change a numeric by the procedure mentioned in the above “(1) Setting of calibration curve number 2) and 3)” and store it with **ENT** key.

#### (3) Setting of data number, sample data $x_n$ and sample data $y_n$

- 1) Press **SEL** key to enter into the data number setting mode.
- 2) Change a numeric by the procedure mentioned in the above “(1) Setting of calibration curve number 2) and 3)” and store it with **ENT** key.
- 3) After setting the above, press **SEL** key for entering into the sample data  $x_n$  setting mode.
- 4) After setting the above, press **SEL** key for entering into the sample data  $y_n$  setting mode.
- 5) After setting the above, press **CH/.** key to return to “1) Data number setting mode” and then set the next data number.
- 6) Repeat the above procedures for setting all junction point data.

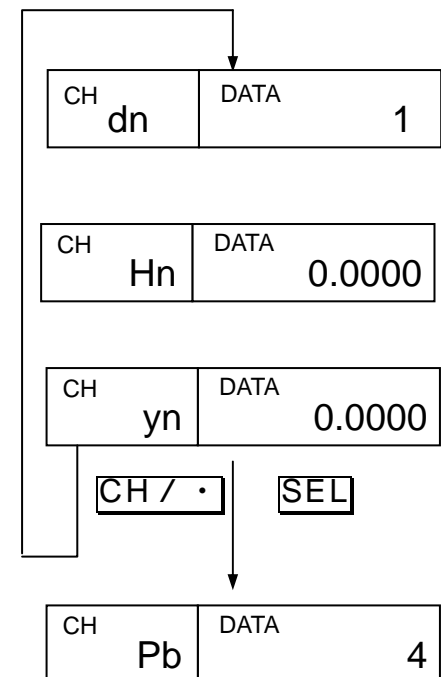

#### (4) Regression/Knee point line

- 1) After completing the setting of knee points, press **SEL** key to enter into the regression/knee point line setting mode.
- 2) Enter “4” in the selection of regression/knee point line.
- 3) After the settings are completed, press **SEL** key for 2 seconds to return to the measurement mode. Automatic return to the measurement mode is made if any key is operated for 1 minute.

## 6. Operation

### 6.5 Setting of operating conditions (Except model for IR-M17□□□N)

#### Reference

When using models except for “IR-M17□□□N”, the following setting can be done from “Detector unit ” or "Setting display unit”.  
Set from "Setting display unit”, if using “IR-M17□□□N”.

Set the operating conditions including time constant and decimal place in the display.

#### 6.5.1 Setting data: Set the following data in operating conditions.

However, the number of displayed setting data varies depending on the setting of dipswitches.

Data name	Display	Setting range	Default value	Remarks
(1) Time constant	t	0 to 9.9 to 99	0.0	Unit: Seconds
(2) Hold ON/OFF	Hd	ON, OFF	OFF	
(3) Preset output ON/OFF	PS	ON, OFF	OFF	
(4) Decimal place in display	Dt	0 to 4	1	
(5) Detector unit number	Hn	1 to 9	1	
(6) Communications speed *1	SP	1200, 2400, 4800, 9600, 19200	9600	
(6) Parity *1	P	nonE odd EVEN	EVEN	nonE :Non parity odd :Odd parity EVEN :Even parity
(6) Data length *1	D	7, 8	7	
(6) Stop bit length *1	B	1 to 2	1	
(6) BCC enable/disable *1	Bc	ON, OFF	OFF (disable)	
(7) Sample temperature correction enable/disable	St	ON, OFF	OFF (disable)	
(8) Correction input scaling L*2	TL	-999 to 999	0	
(8) Correction input scaling H*2	TH	-999 to 999	100	
<b>[ Engineering mode ]</b>				
(9) Weight	Af	0 to 1.000	0.500	
(10) Calibration constant k1	k1	0 to ±9.9999	1.0000	
(11) Calibration constant k2 *3	k2	0 to ±9.9999	0.0000	

**Note )**The setting data of \*1 to \*3 is displayed or not depending on the setting of dipswitches.

Displayed data	Setting of dipswitch 1	Contents
*1 Setting data	No. 4 : ON	Connection destination: Personal computer
*2 Setting data	No. 7 : ON    No. 8 : OFF	Corrected input: Enable Corrected input specification: 4 to 20mADC
*3 Setting data	No. 3 : ON	No. 2 Calibration: Enable

**(1) Time constant:** If a measured value fluctuates noticeably, the signal can be set to be dull by delaying the response of this thickness meter. Set the smoothing time (equivalent to the time constant of analog instrument) in 0.1-second increment for less than 10 seconds and in 1-second increment for more than 10 seconds.

**(2) Hold ON/OFF:** When holding of measured value is desired, turn it ON. At this time, analog output will also be held.

## 6. Operation

- (3) **Preset output ON/OFF:** By turning on the preset output, this thickness meter displays the preset thickness value and the analog output becomes the value corresponding to the preset thickness value.
- (4) **Decimal place in moisture display:** The decimal place can be set for easily monitoring the thickness value measured.
- (5) **Detector unit number:** This is the number for identifying the detector unit for connection of multiple detector units. This setting has been completed in [6.2 Setting of detector unit number].
- (6) **Communications speed, Parity, Data length, Stop bit length, BCC enable/disable:** These are for communications with a personal computer, a sequencer or other similar devices. These data are not necessary to set for combining this thickness meter with the setting display unit.
- (7) **Sample temperature correction enable/disable:** These are used for sample temperature correction enabled.
- (8) **Correction input scaling L, Correction input scaling H:** These are used for scaling of 4 to 20mA correction input.
- (9) **Weight  $\alpha$ :** In 3-wavelength operation, the ratio of 2 comparative wavelengths is determined by this value. For model IR-M1700, set the weight to 1.000.
- (10) **Calibration constant K1:** This is the calibration constant at the time of zero side calibration.
- (11) **Calibration constant k2:** This is the calibration constant at the time of span side calibration.

### 6.5.2 Setting

- Press **SEL** key and **ENT** key simultaneously for 2 seconds to enter into the operation condition setting mode.
- By pressing **▶** key, a numeric blinks for entering a data.
- Change the numeric by **▲** key, **▼** key or **▶** key. When **▶** key is pressed, the blinking digit shifts. For entering the decimal point, press **CH./** key.
- When **ENT** key is pressed, the numeric stops blinking and the data is stored.
- Press **SEL** key to enter into the setting mode of the next data. Repeat the above procedures to set all data except the engineering mode.
- For setting of data in the engineering mode, press **ENT** key in the screen shown in the right side to enter into the setting mode of the engineering mode.
- After the settings are completed, press **SEL** key for 2 seconds to return to the measurement mode. Automatic return to the measurement mode is made if any key is operated for 1 minute.

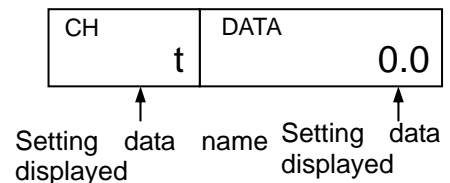

## 6. Operation

### 6.6 Calibration (Except model for IR-M17□□□N)

#### Reference

When using models except for "IR-M17□□□N", the following setting can be done from "Detector unit" or "Setting display unit".  
Set from "Setting display unit", if using "IR-M17□□□N".

For using this thickness meter accurately, regular calibration once in three months is requested.

- 1) Supply power more than one hour to this moisture meter before calibration.
- 2) Turn the calibration curve number to 0. (For the change in calibration curve number, refer to [6.7 Setting of calibration curve number]. By this setting, absorbance "x" is displayed as a data.
- 3) Mount the output checker plate to the tip of the air purge hood, and face No.1 side of output checker plate.
- 4) Execute the calibration by pressing the three keys **SEL**, **▽**, and **ENT** simultaneously.

Make sure that light absorbance "x" is within  $0.00000 \pm 0.0010$  in the model of IR-M1700 and IR-M1200.

The calibration is completed.

CH	DATA
0	0.0021

CH	DATA
0	0.0000

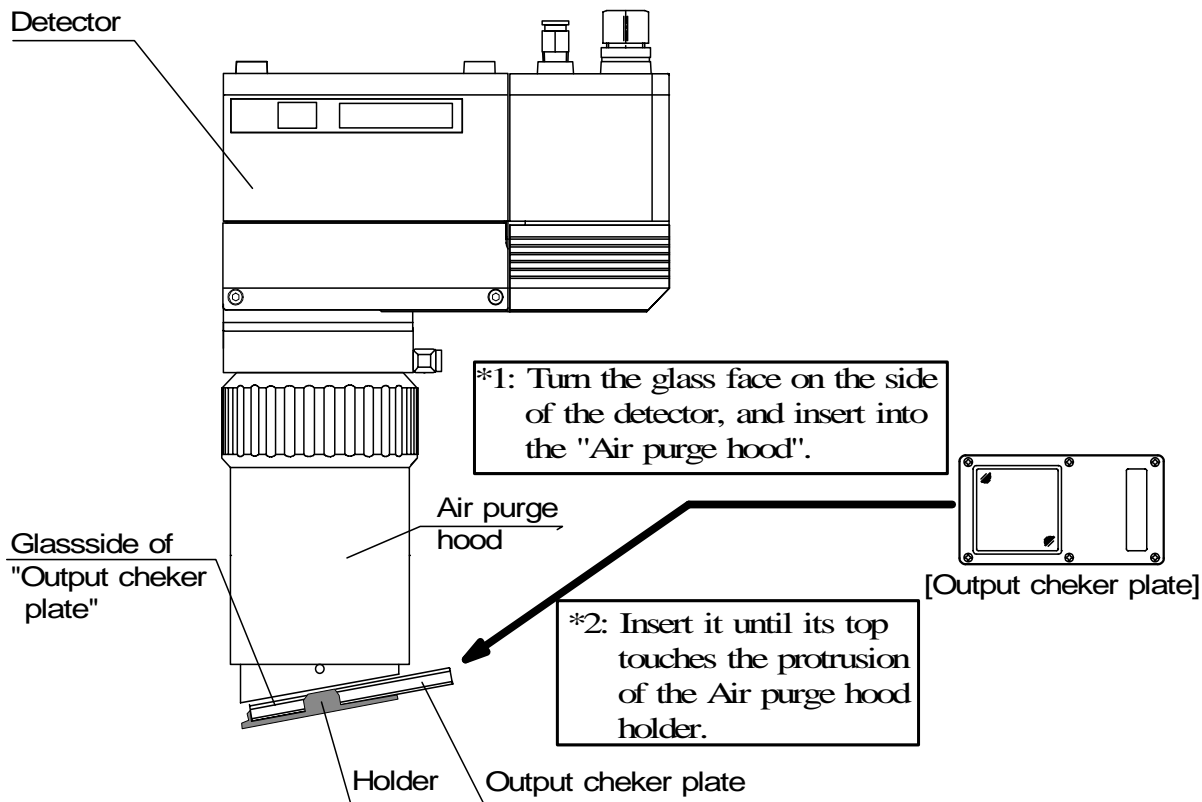

## 6. Operation

### 6.7 Setting of calibration curve number

(Except model for IR-M17□□□N)

#### Reference

When using models except for “IR-M17□□□N”, the following setting can be done from “Detector unit ” or "Setting display unit”.  
Set from "Setting display unit”, if using “IR-M17□□□N”.

Set the calibration curve number according to the measuring object.

- 1) By pressing **CH/.** key, a numeric blinks for entering a calibration curve number.
- 2) Change the numeric by **Δ** key, **▽** key or **▶** key.
- 3) When **ENT** key is pressed, the numeric stops blinking and this thickness meter becomes the measurement mode at the calibration curve number changed.

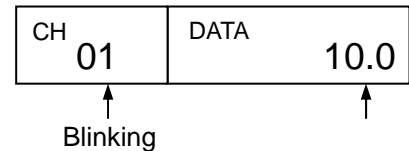

### 6.8 Correction of calibration curve (Except model for IR-M17□□□N)

#### Reference

When using models except for “IR-M17□□□N”, the following setting can be done from “Detector unit ” or "Setting display unit”.  
Set from "Setting display unit”, if using “IR-M17□□□N”.

If the actual thickness value is different from the thickness value being preset due to the difference of one-line and off-line, or other causes, correct it by the correction coefficients  $b_0$  and  $b_1$  in [6.3 Setting of calibration curve data]. Usually, the shift correction is done with  $b_0$  only.

#### Reference

##### [Example]

When the measured thickness before correction is 25.0( $\mu\text{m}$ ) and actual thickness value is 23.5( $\mu\text{m}$ ), Set  $b_0 = -1.5(\mu\text{m})$  .

## 7. Creation of calibration curves

### 7. Creation of calibration curves

The output characteristics of the thickness meter depend upon the measuring objects. Also, the output characteristics may also change according to the process conditions and thickness measurement conditions of samples for certain measuring objects.

Therefore, for accurate measurement of thickness, it is necessary to carry out the sample tests of each measuring object in advance and obtain the relative relation (this is called as calibration curve) between the thickness value ( $\mu\text{m}$ ) obtained by the drying method or other measuring methods and the absorbance "x" measured by the thickness meter. This chapter describes the measurement of the thickness value by the drying method. However, the method of creation of the calibration curves is same even if the thickness value is measured by the Karl Fischer method or other methods.

#### 7.1 Creation of calibration curves (Except model for IR-M17□□□N)

##### Reference

When using models except for "IR-M17□□□N", the following setting can be done from "Detector unit" or "Setting display unit".  
Set from "Setting display unit", if using "IR-M17□□□N".

Create a calibration curve by plotting data obtained by the above measurement on a graph. Plot the absorbance "x" of this thickness meter on the X-axis and also plot the thickness value ( $\mu\text{m}$ ) on the Y-axis.

Obtain a curve with minimize errors from this graph as a calibration curve. Usually the curve with minimize errors is obtained by the regression operation. For the creation of a calibration curve by the regression operation, refer to [7.1.1 Computation of regression expression] and [7.1.2 Confirmation of regression expression].

If a graph contains inflection points, use the creation of a calibration curve by broken line approximation. For the creation of a calibration curve by broken line approximation, refer to [6.4 Creation of calibration curve by knee point line approximation].

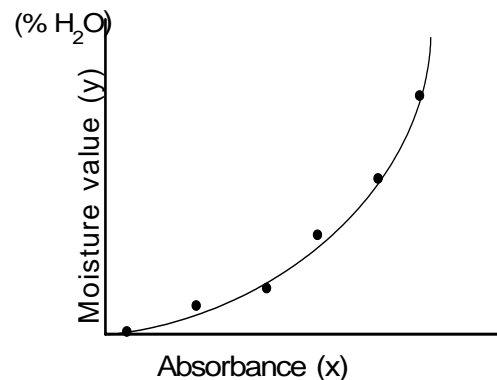

# 7. Creation of calibration curves

## 7.1.1 Computation of regression expression

This thickness meter has regression operation function by the minimum mean square method. By this function, first-degree to third-degree polynomials can be obtained by entering the data obtained in the above measurement on a graph.

Assume that there are “n” sets of sample data ( $x_n, y_n$ ). (in condition that “n” is 20 or less)

### (1) Setting of calibration curve number

- 1) Press **SEL** key and **CH/.** key simultaneously for 2 seconds to enter into the sample data setting mode.
- 2) By pressing **▶** key, a numeric blinks for entering a calibration curve number.
- 3) Change the numeric by **▲** key, **▼** key or **▶** key.  
 When **▲** key is pressed, the numeric is increased.  
 When **▼** key is pressed, the numeric is decreased.  
 When **▶** key is pressed, the blinking digit shifts.
- 4) When **ENT** key is pressed, the numeric stops blinking and the calibration curve number is stored.

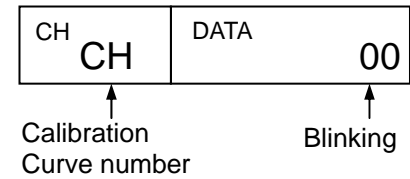

### (2) Setting of data count

- 1) Press **SEL** key to enter into the data count setting mode.
- 2) Change a numeric by the procedure mentioned in the above “(1) Setting of calibration curve number 2) and 3)” and store it with **ENT** key.

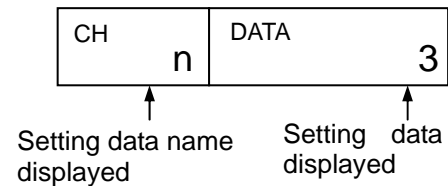

### (3) Setting of data number, sample data $x_n$ and sample data $y_n$

- 1) Press **SEL** key to enter into the data number setting mode.
- 2) Change a numeric by the procedure mentioned in the above “(1) Setting of calibration curve number 2) and 3)” and store it with **ENT** key.
- 3) After setting the above, press **SEL** key for entering into the sample data  $x_n$  setting mode.
- 4) After setting the above, press **SEL** key for entering into the sample data  $y_n$  setting mode.
- 5) After setting the above, press **CH/.** key to return to “1) Data number setting mode” and then set the next data number.
- 6) Repeat the above procedures for setting all sample data.

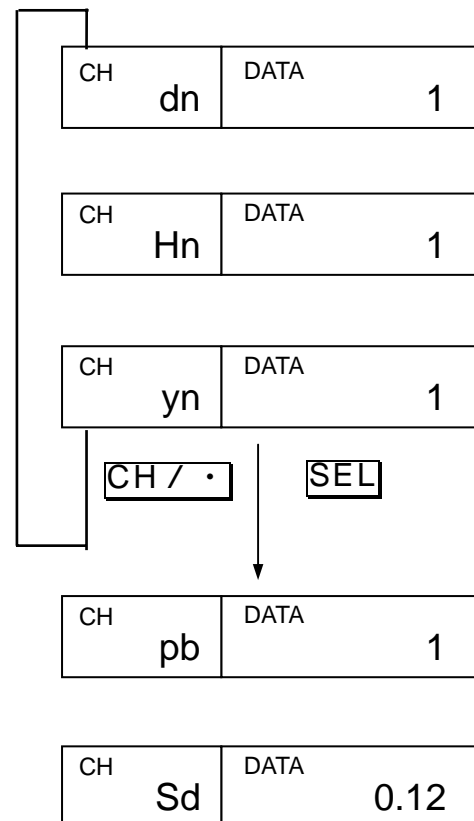

## 7. Creation of calibration curves

### 7.1.1 Computation of regression expression

#### (4) Computation of regression expression

- 1) After completing the setting of sample data, press **SEL** key to enter into the regression/broken line setting mode.
- 2) Enter “1, 2 or 3” in the selection of regression/broken line. A polynomial with corresponding degree can be obtained.
- 3) By pressing **SEL** key, the standard deviation (approximate accuracy of the regression expression) of the above regression expression is displayed.
- 4) After the settings are completed, press **SEL** key for 2 seconds to return to the measurement mode.  
Automatic return to the measurement mode is made if any key is operated for 1 minute.

### 7.1.2 Confirmation of regression expression

The coefficient of the regression expression obtained by the above can be confirmed by the following procedure.

- 1) Press **SEL** key for 2 seconds to enter into the calibration curve setting mode.
- 2) Set calibration curve number, for which the regression expression is obtained.
- 3) Press **SEL** key to display the coefficient  $a_0$  of the regression expression.
- 4) For displaying  $a_1$  to  $a_3$ , press **SEL** key in the same way.
- 5) After the confirmation is completed, press **SEL** key for 2 seconds to return to the measurement mode.  
Automatic return to the measurement mode is made if any key is operated for 1 minute.

CH	CH	DATA	1
----	----	------	---

CH	A0	DATA	1.2544
----	----	------	--------



## 8. Correction function by sample temperature from external input

### 8.1 Summary

When a calibration curve changes at the sample temperature  $T_s$ , this function enables to change the calibration curve to other one at this sample temperature. For the input of the sample temperature, a platinum resistance thermometer (Pt100), a radiation thermometer or a temperature/voltage converter with the output of 4 to 20mADC can be used. By utilizing this function, 10 calibration curves in one group (9 curves only in the group 10) are changed with the sample temperature  $T_s$ . Since 99 calibration curves can be stored, up to 10 groups can be set.

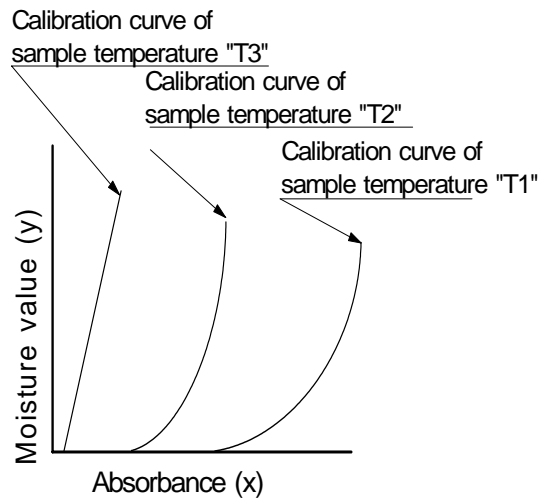

### 8.2 Model

This is an optional function. The model number of the detector unit with this optional function is as follows: **IR-M17** □ □ □

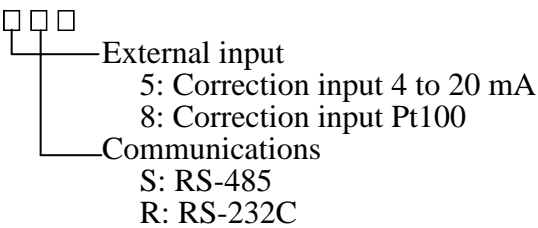

### 8.3 Wiring of detector unit

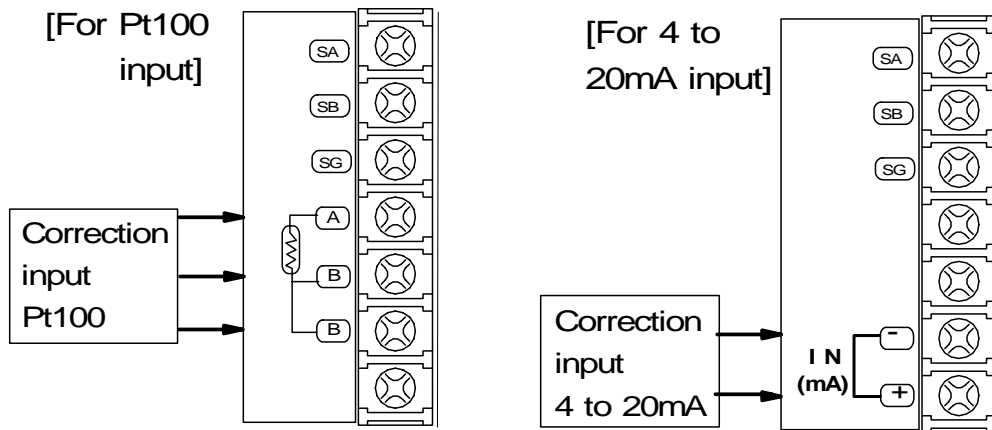

### 8.4 Setting of dipswitch (Ref to [3.1 Setting of dipswitches])

- (1) Turn off the power supply of the detector unit and the setting display unit.
- (2) Switch the dipswitch 7 (Correction input enable/disable) of the detector unit to ON side.
- (3) **For 4 to 20mA input:** Switch the dipswitch 8 (Correction input) to OFF side (4 to 20mADC).

**For Pt100 input:** Switch the dipswitch 8 to ON side (Pt100).

- (4) Turn on the power supply of the detector unit and then turn on the power supply of the setting display unit.

## 8. Correction function by sample temperature from external input

### 8.5 Setting of correction enabled/disabled by sample temperature

Execute this setting to either the detector unit or the setting display unit. When the correction is disabled, the operation is normal which means the calibration curve is not changed according to the sample temperature. When it is enabled, the calibration curve is changed with the sample temperature.

#### 8.5.1 Setting at the detector unit

- (1) Enter into the operating conditions setting mode.

**SEL** + **ENT** for 2 seconds

CH	DATA
<b>St</b>	<b>OFF</b>

- (2) Enter into the correction enable/disable setting mode

(St). **SEL** Several times

- (3) Select the correction enabled or disabled.

**▶** **▼** **ENT** (OFF) Correction OFF (disable)  
**▶** **▲** **ENT** (ON) Correction ON (enable)

- \* For the setting of sample temperature scaling as the next step, skip (4) and step to (2) of [8.4 Setting of sample temperature scaling].

- (4) Return to the measurement mode.

**SEL** for 2 seconds

#### 8.5.2 Setting at the setting display unit

- (1) Set the calibration curve number to 0.

**CH** **0** **ENT**

- (2) Enter into the correction enable/disable setting mode (St).

**MODE** **1** **9** **ENT**

- (3) Select the correction enabled or disabled.

**0** **ENT** (OFF) Correction OFF (disable)  
**1** **ENT** (ON) Correction ON (enable)

- \* For the setting of sample temperature scaling as the next step, skip (4) and step to (2) of [8.4 Setting of sample temperature scaling].

- (4) Return the calibration curve number to the original one.

## 8. Correction function by sample temperature from external input

### 8.6 Setting of sample temperature scaling (Only 4 to 20mA DC)

In case of using radio thermometer or thermoelectric converter, it is necessary to match the temperature range of their 4 to 20mA DC output and the temperature range of 4 to 20mA DC input of this instrument.

Carry out scaling in either detector unit side or setting display unit side, following the main points given below.

#### 8.6.1 Setting at the detector unit

- (1) Enter into the operating condition setting mode.

**SEL** + **ENT** for 2 seconds

CH	DATA
<b>tL</b>	<b>0.0</b>

- (2) Enter into the setting mode of sample temperature scaling low limit (tL).

**SEL** Several times

- (3) Set the low limit (tL) of sample temperature scaling.

(Setting range: -999.9 to 999.9)

- (4) Enter into the setting mode of sample temperature scaling high limit (tH). **SEL** Once

- (5) Set the high limit (tH) of sample temperature scaling.

(Setting range: -999.9 to 999.9)

#### 8.6.2 Setting at the setting display unit

- (1) Set the calibration curve number to 0.

**CH** **0** **ENT**

- (2) Enter into the sample temperature scaling setting mode

**MODE** **2** **1** **ENT**

- (3) Set the low limit (tL) of sample temperature scaling.

(Setting range: -999.9 to 999.9)

- (4) Enter into the setting mode of sample temperature scaling high limit (tH). **SEL** Once

- (5) Set the high limit (tH) of sample temperature scaling.

(Setting range: -999.9 to 999.9)

### 8.7 Setting of sample temperature

The key operation for this setting is common on the detector unit and the setting display unit.

- (1) Enter into the calibration curve setting mode.

**SEL** for 2seconds

- (2) Enter into the sample temperature setting mode (tS).

**SEL** several times

- (3) Set the sample temperature. (Setting range: -999.9 to 999.9)

CH	DATA
<b>tS</b>	<b>999.9</b>

**8. Correction function by sample temperature from external input****8.8 Setting of calibration curve data**

- (1) Specify a group for calibration curve number to be used.

The groups are from 1 to 10 and each one corresponds to the following calibration curve numbers respectively.

Group 1: Calibration curve number 1 to 10

Group 6: Calibration curve number 51 to 60

Group 2: Calibration curve number 11 to 20

Group 7: Calibration curve number 61 to 70

Group 3: Calibration curve number 21 to 30

Group 8: Calibration curve number 71 to 80

Group 4: Calibration curve number 31 to 40

Group 9: Calibration curve number 81 to 90

Group 5: Calibration curve number 41 to 50

Group 10: Calibration curve number 91 to 99

- (2) Example: Select the group 1.

Set the following calibration curve at the sample low limit temperature T1 to the calibration curve No. 1.

$$Y = a3X^3 + a2X^2 + a1x + a0$$

Only the calibration curve by polynomial expression can be used. (The calibration curve by broken line approximation cannot be used.)

Further, set the sample temperature T1. For its setting, refer to [8.7 Setting of sample temperature].

- (3) Set the calibration curves at the sample temperature Ti (i= 2 to 10) to the calibration curve numbers 2 to 10.

However, Ti should fulfill the following expression.

$$T1 \text{ (Sample low limit temperature)} \leq T2 \leq \dots \leq T9 \leq T10 \text{ (Sample high limit temperature)}$$

- (4) Enter 999.9 at the Ti, which is not used. Be careful that, if this value is not entered, a calibration curve not used is computed as a data.

\* The default of the sample temperature Ti is 999.9.

- (5) For the correction expression coefficients b1 and b0 and the constants (low limit range, high limit range, low limit alarm, high limit alarm and preset value), use the values for the first calibration curve number in a group.

Group 1: Calibration curve number 1

Group 6: Calibration curve number 51

Group 2: Calibration curve number 11

Group 7: Calibration curve number 61

Group 3: Calibration curve number 21

Group 8: Calibration curve number 71

Group 4: Calibration curve number 31

Group 9: Calibration curve number 81

Group 5: Calibration curve number 41

Group 10: Calibration curve number 91

## 8. Correction function by sample temperature from external input

### 8.9 Measurement

- (1) When the correction by sample temperature ON (enable) is selected and one calibration curve number in a group is set, the calibration curve number changes automatically corresponding to sample temperature.

For example, when the sample temperature  $T_s$  fulfills the following expression, the calibration curve number becomes “i”.

$$T_1 \leq \dots \leq T_i \leq T_s < T_{i+1} \leq \dots \leq T_{10}$$

- (3) However, the measured value  $Y$  is not the measured value  $T_i$  on the calibration curve No. “i”. The measured value  $Y$  becomes the following value interpolated from the measured value  $Y_i$  and the measured value  $Y_{i+1}$  on the calibration curve No. “i+1”.

$$Y = (Y_{i+1} - Y_i) \times \frac{T_s - T_i}{T_{i+1} - T_i} + Y_i$$

- (3) When the sample temperature  $T_s$  is lower than the sample temperature of the first calibration curve number in the group or when it is higher than the sample temperature of the last calibration curve number, the following error display appears.

However, the calibration curve, of which sample temperature is set as 999.9, is ignored.

\* For the sample temperature lower than the sample temperature of the first calibration curve number in the group Er15 (Sample temperature too low)

\* For the sample temperature higher than the sample temperature of the first calibration curve number in the group Er14 (Sample temperature too high)

### 8.10 Display of sample temperature $T_s$

#### 8.10.1 Display at the detector unit

- (1) Set the calibration curve number to 0. CH 0 ENT
- (2) For canceling of the sample temperature display SEL for 2 seconds or CH 2 for seconds

#### 8.10.2 Display at the setting display unit

- (1) Set the calibration curve number to 0. CH 0 ENT
- (2) For displaying the sample temperature display MODE 2 0 ENT
- (3) For canceling of the sample temperature display SEL for 2 seconds or CH for 2 seconds

## 9. Inspection and maintenance

### 9.1 Periodical inspection

The following inspection is required periodically.

#### (1) Cleaning of detector cover glass surface:

Keep the detector cover glass surface clean all times. Wipe off dirt and flogging with gauze or the like. If the gauze is dipped in alcohol, it is more effective.

#### (2) Installation: Check the detector unit is installed firmly.

#### (3) Connections: Check the connections to the terminals of the detector unit, the setting display unit and other instruments are connected completely.

#### (4) Feed air for air purge:

Check the feed air flow, air pressure, and cleanness of air before starting air purge.

#### (5) Calibration: Regular calibration one in 3 months required by using the output checker plate.

Model IR-WEB : For IR-M7100

## *9. Inspection and maintenance*

### 9.2 Self-diagnosis function

Error message for abnormal operation is displayed by the self-diagnosis function.

The same error message is displayed in the detector unit and the setting display unit.

Error No.	Item	Contents	Measures	Self-diagnosed abnormality
-----	High limit over range	Measured value is higher than display range.	Check calibration curve data. Check output by checker plate.	---
-----	Low limit over range	Measured value is lower than display range.	Check calibration curve data. Check output by checker plate.	---
Er01	Calibration data error	Calibration data is damaged.	Clear RAM.	○
Er02	RAM error	Detector unit ram data is damaged.	Clear RAM.	○
Er03	Motor rotation abnormal	Motor stops or rotates abnormally.	Exchange motor.	○
Er04	Lamp power supply abnormal	Lamp power supply is damaged.	Exchange lamp power supply unit.	○
Er05	A/D abnormal	A/D is over range.	Check output by checker plate.	○
Er06	Computation error	Computation is overflow.	Check output by checker plate.	○
Er07	Element temperature abnormal	Element temperature is abnormal.	Need to return detector unit to CHINO.	○
Er10	Calibration curve data error	Calibration curve data is not appropriate.	Reset calibration curve data.	---
Er11	Knee point line approximation error	Absorbance x is out of range of broken line approximation.	Reset broken line approximation data.	---
Er12	Ambient temperature too high	Ambient temperature of detector unit is too high	Lower ambient temperature.	---
Er13	Ambient temperature too low	Ambient temperature of detector unit is too low	Raise temperature.	---
Er14	Sample temperature too high	Sample temperature is higher than correction range	Widen correction range.	---
Er15	Sample temperature too low	Sample temperature is lower than correction range	Widen correction range.	---
Er16	Sample low reflection	Reflection rate of sample is low or the lamp is damaged.	Close distance to sample. If the lamp is damaged, exchange it.	---
Er17	Regression operation error	Regression operation is abnormal.	Check calibration curve sample data.	---

**(Note)** For the items filled with ○ in the self-diagnosed abnormality, an alarm output for self-diagnosed abnormality is activated from the setting display unit.

## **9. Inspection and maintenance**

### **9.3 Measures against troubles not included in self-diagnosis**

If a trouble occurred, take remedial measures referring to the corresponding items of this instruction manual after checking the following points. For the troubles of the setting display unit, refer to the separate instruction manual the setting display unit.

#### **[1.] No display appears in detector unit. (Except model for IR-M17□□□N)**

- (1) Is the power supply normal?
- (2) Is the fuse normal?
- (3) Are cables connected completely?
- (4) Are connectors connecting the setting display part and the internal CPU board connected securely?
- (S) Turn off the power supply once and turn it on again.
- (6) If the trouble cannot be repaired by the above check, the power supply unit in the detector may be defective.

#### **[2.] Measured value remains unchanged.**

- (I) Is HOLD set to OFF?
- (2) Is PRESET set to OFF?
- (3) Are the calibration curve data correct?
- (4) Turn off the power supply once and turn it on again.
- (5) By using the output checker plate, check the display changing at the calibration curve number 0.
- (6) Try RAM CLEAR if no change occurs. If the trouble can not be recovered yet, send back for repair.

#### **[3.] Measured value fluctuates.**

- (1) Is the measuring surface flat?
- (2) Is the measuring position correct? Make sure that the detector unit does not measure a bottom face like as a belt conveyor.
- (3) Make sure that the disturbance light does not radiate onto the measuring surface.
- (4) Is the smoothing time proper? Certain smoothing time is necessary for stable measurement.
- (5) Make sure that any noise source does not exit around the detector unit or connection cables.
- (6) By using the output checker plate, check if the display at the calibration curve number 0 fluctuate.
- (7) If the display fluctuates in (6), clear RAM. If the trouble is not recovered yet, send back it to CHINO for repair.

#### **[4.] Measured value is slightly higher than or lower than the actual value.**

- (1) Is the calibration curve number correct?
- (2) Are the calibration curve data correct?
- (3) Are HOLD and PRESET set to OFF?
- (4) Is the measuring position correct?
- (5) Is the detector cover glass surface of dirt and fogging?
- (6) Correct the calibration curve. (Refer to [6.8 Correction of calibration curve])

## 9. Inspection and maintenance

### 9.4 Maintenance parts

#### 9.4.1 List of maintenance parts

The replacing intervals are reference values. They vary according to the working condition.

Article name	Quantity	Replacing interval	Remarks
Light source lamp (With connector)	1	5 years	
Motor (with connector)	1	3 years	
Fuse	2		Attached as an accessory
Lithium battery (mounted on a printed circuit board)	1	3 years	3 years when no power is fed
Power supply unit (Note)	1	5 years	3 years when the ambient temperature is 40°C or higher

(Note): This is built in the detector unit. (not IR-WEP)

#### **Warning**

For replacing maintenance parts, make sure to turn off the power source.

#### 9.4.2 Replacement of light source lamp

- (1) Turn off the power supply to the detector.
- (2) Loosen four M4 hexagon socket head bolts of the lamp cover and remove the lamp cover.
- (3) Disconnect the lamp connector, and remove the lamp by loosening the lamp fixing screws (M3 pan head screws).
- (4) Fix the new lamp to the case temporarily by the lamp fixing screws with washers, and connect the connector.
- (5) Mount the air purge hood to the detector. Set the hood length to such an extent as the output checker plate holder is hidden (about 230mm).
- (6) Stick a plotting paper for tracing at the hood tip to project the lamp image on the plotting paper. In this case, stick it so that the center of the hood circle can be discriminated.
- (7) Light the lamp by turning on the lamp power supply.
- (8) Position the lamp image at the center of the plotting paper by moving the lamp holder vertically and horizontally.
- (9) Reset the lamp cover as before. Now, the lamp exchange is completed.

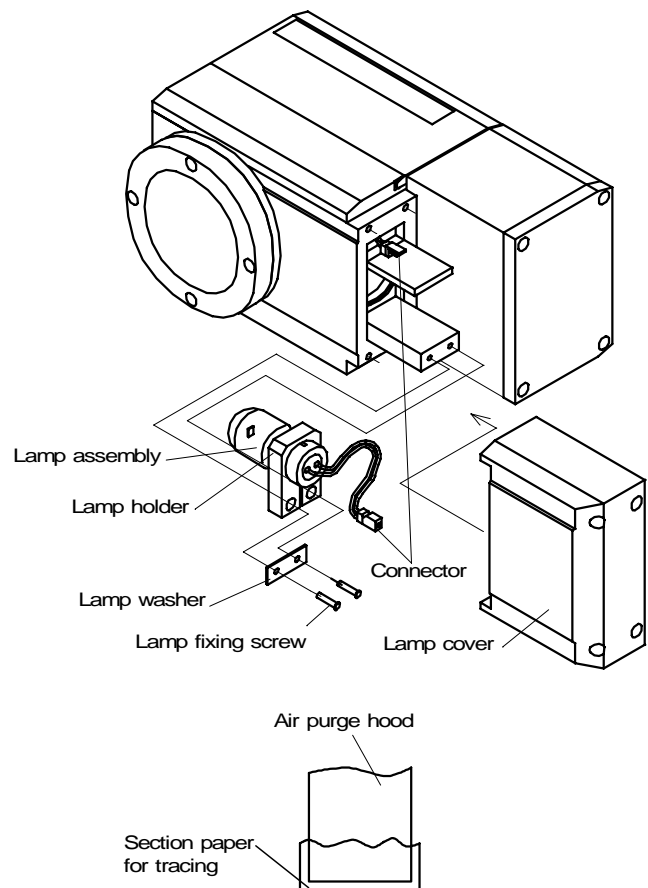



## 9. Inspection and maintenance

### 9.4.3 Replacement of motor

- (1) Turn off the power supply to the detector.
- (2) Remove the measuring part cover by loosening the M4 hexagon socket head bolts or M4 pan head screws fixing the measuring part cover.
- (3) The measuring part cover of the specifications with keys and display is connected to the interior by a cable. Disconnect the display unit connector shown in the figure by lifting the cover with due care so as not to damage the cable.
- (4) Remove the rubber ring that fixes the motor lead wire.
- (5) Loosen the motor fixing screws and remove the motor band by pulling it toward you while holding the motor.
- (6) After lifting the motor, disconnect the motor connector below the motor, and then, remove the motor unit from the case.
- (7) After erecting the motor unit as illustrated, hold the sector lightly, and separate the sector from the motor by removing four M2 screws which fix the sector.
- (8) Erect the new motor to be replaced, and mount it, while taking care of the front and rear sides of the sector.
- (9) Connect the lead wire of the motor to the connector.
- (10) Cover the motor with the motor band after placing the motor so that its tip touches the stopper of the motor mounting base. (In this case, position the motor lead wire as the illustrated position.)
- (11) Fix the motor band with the motor fixing screws.
- (12) Mount the motor ring to the motor lead wire as shown in the figure. Be careful not to allow the lead wire to interrupt the optical path.
- (13) Reset the measuring part cover as before. Now, the motor has been replaced. (Insert the cover cable connector in case of the specifications with keys and display.)

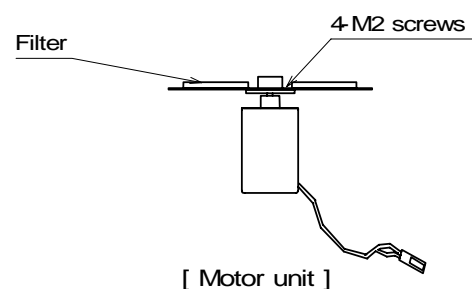
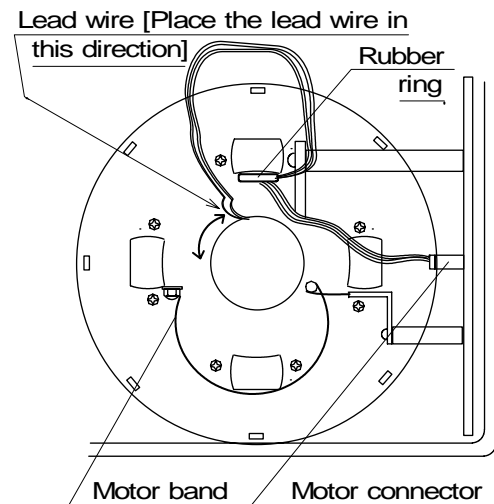
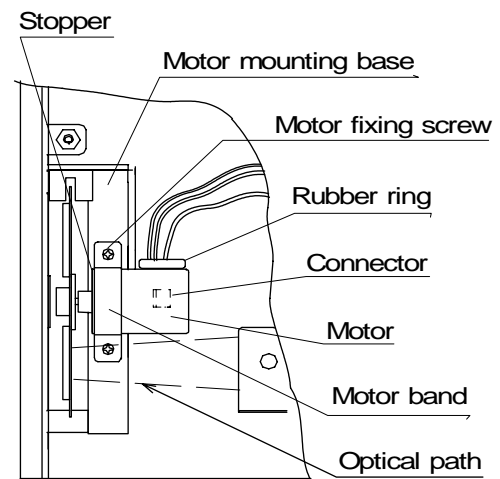
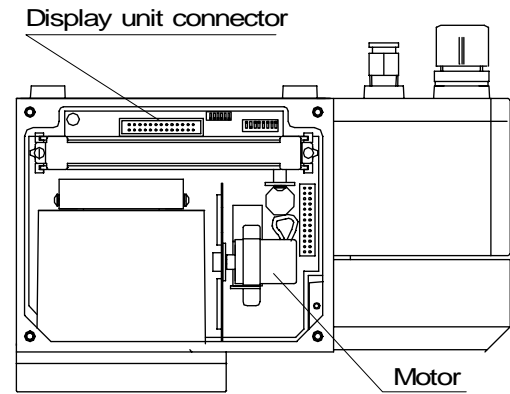

### Caution

Never scratch the sector filter during replacement of the motor.

## 9. Inspection and maintenance



### 9.4.4 Replacement of lithium battery

The detector unit has a built-in lithium battery for memory backup. The setting data are kept, even if electricity is not supplied for 3 years or longer. When the battery has been consumed after 3 years or longer without supplying electricity, replace it with a new battery by the following procedure.

- (1) Turn off the power source to the detector unit.
- (2) Open the door of detector unit and take out the setting display part by removing four screws fixing it.
- (3) The setting display part is connected with the interior by a cable. Lift the cable with care not to damage it and disconnect the connector for the setting display part as shown in the figure.
- (4) Take out the holder for the PCB board by loosening 2 M2.6 pan head screws.
- (5) Pull the A/D board forward.
- (6) Replace the lithium battery with the mounting board by removing fixing screws for the mounting board placed on the A/D board.

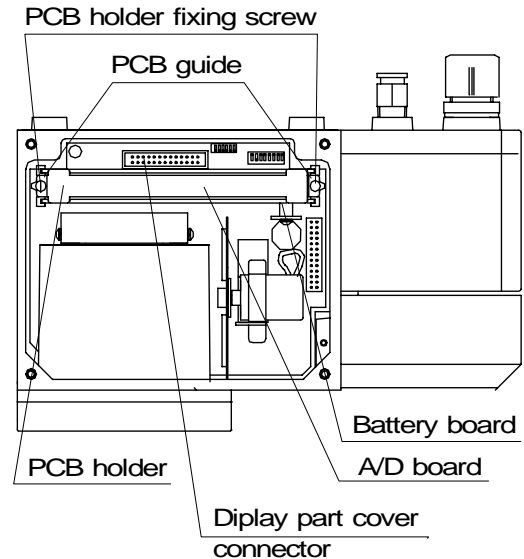

#### Warning

Make sure polarities of the battery are correct.

- (7) Insert the A/D board to the lower connector along the guide completely.  
Return the holder for the PCB board and the door to the original positions.

## 9. Inspection and maintenance

### 9.4.5 Replacement of power supply unit

- (1) Turn off the power source to the detector unit.
- (2) Open the door of detector unit.
- (3) Disconnect the connection cable and take out the connection cable from the cable inlet.
- (4) Pull out the output board from the case inside by loosening two M3 pan head screws and by disconnecting the connector (14-pin).
- (5) Pull out the power supply unit by loosening M3 nut and two M3 pan head screws and by disconnecting two connectors (10-pin, 2-pin).
- (6) Connect the connector to a new power supply unit and assemble it by reversing the removing procedure. Be careful not to step the connection cable.
- (7) Connect the connector to the output board taken out and fix it to the case inside.
- (8) Connect the connection cable and return the door to the original position.

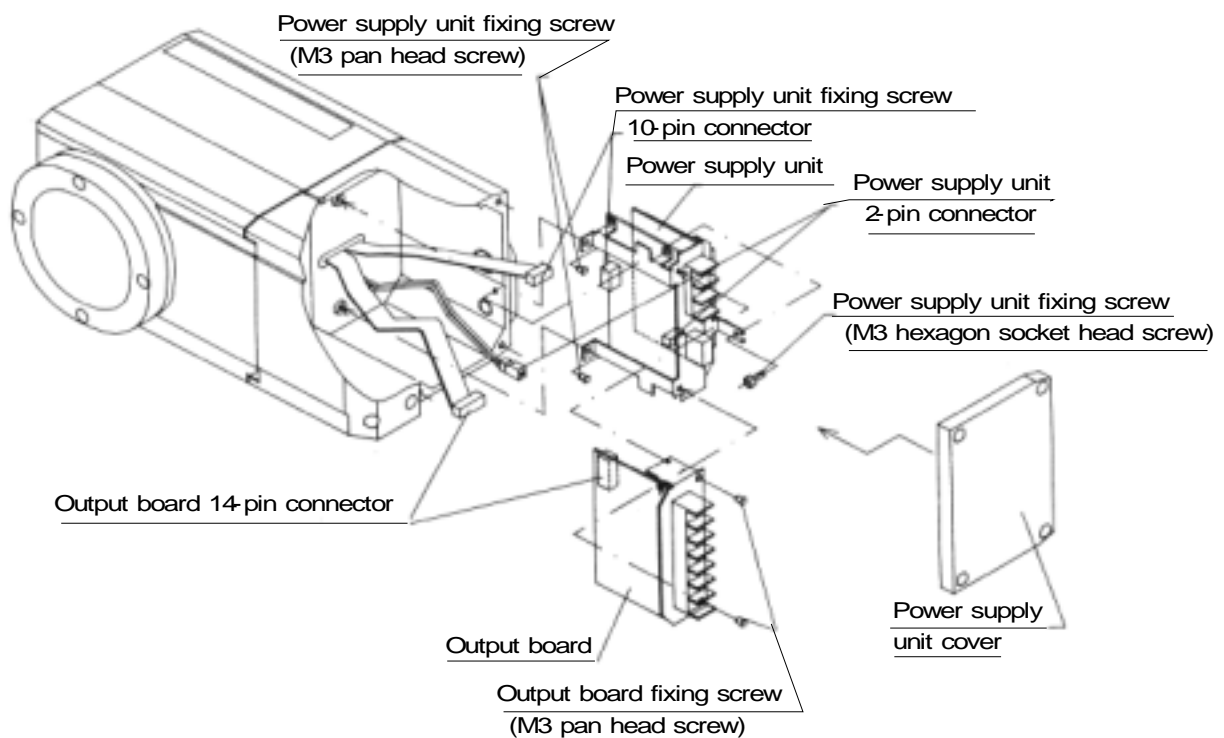

### 9.5 RAM clear

Try clearing the RAM contents, if a detector trouble cannot be repaired by all means.

#### 9.5.1 RAM clear (Except model for IR-M17□□□N)

- (1) Turn on the power supply by pressing **SEL** and **△** keys together.
- (2) The RAM contents have been initialized. Reset the calibration curve data, etc. again.

**Caution**

For Model IR-M1700 set the weight "α" to 1.000.  
Refer to [5.5 Setting of operation conditions]

#### 9.5.2 RAM clear (Only model for IR-M17□□□N)

- (1) Turn on the power supply after turning on all No. 1 to No. 4 switches of DIP switches 2.  
(Refer to [3.1 Setting of DIP switches])
- (2) Reset the setting of DIP switches as before.
- (3) The RAM contents have been initialized. Reset the calibration curve data, etc. again

**Caution**

For Model IR-M1700 set the weight "α" to 1.000.  
Refer to [5.5 Setting of operation conditions]

## ***10. Specifications and external dimensions***

### **10. 1 Detector**

#### **10.1.1 Specifications of the detector**

	<b>IR-M17□□□□</b>
Measuring system	Infrared reflection type 2-wavelength system
Measuring distance	300mm (Mountable within a range of 200 to 400mm)
Measuring area	50*50mm (at a measuring distance of 300mm). For small diameter 30 x 30mm (optional)
Reproducibility	Detector output " x " value $\pm 0.003$ with the output checker plate (under the same ambient temperature and humidity conditions). The above reproducibility is specified with the output checker plate and it is different from the reproducibility in actual measurement.
Thickness output	4 to 20mADC (Load resistance Lower than 500 )
Output accuracy	$\pm 0.5\%$ FS
Correction input (Optional)	4 to 20mADC (option for correcting the sample temperature, measuring distance, etc.) The correction input specification does not contain any thickness output.
Communication output	RS-485, RS-232C or RS-422A is designated.(RS-485, if the unit is combined with the setting display unit.)
Output update cycle	28ms
Display	Data : LED 5 digits Calibration curve number : LED 2 digits
Setting	Keys or communication
Calibration curve	Polynomials of the degree one to three or knee point data
Number of calibration curves	99
Calibration curve correction	Zero and span correction
Creation of calibration curve	Regression operation
Smoothing	0 to 99sec (Every 0.1sec in case of shorter than 10 seconds or every second in case of longer than 10 seconds)
Calibration	Executed with the output checker plate
Self-diagnosis	Calibration data error, RAM error, motor rotation error, lamp power down, communication error, high or low ambient temperature, sample low reflection, etc. are output by LED display or communication.
Working temperature range	0 to 50°C (Air cooling is necessary if the ambient temperature is higher than 45°C)
Power voltage	24VDC, (Applicable to CE-marking conformance product only 24V DC $\pm 10\%$ )
Allowable voltage fluctuation	18 to 30VDC
Power consumption	Max. approx.36VA, (Applicable to CE-marking conformance product only Max. approx.10VA)
Allowable vibrations	3G or less
Connection	Terminal connection
Case	Aluminum drip-proof structure (Conforming to IEC529 IP65)
Mounting method	Bolt suspension method with four M8 bolts
Weight	Approx. 4kg
Accessories	Power supply unit IR-WEP 1 unit. Fuse 2 pcs.L-hexagonal wrench key 2 pcs. Ferrite core 2 pcs. (Attached to CE-marking conformance product only)
Analog output (Applicable to CE-marking conformance product only )	4 to 20mADC (Load resistance Lower than 500 ) 1 output [1] Output accuracy: $\pm 0.5\%$ FS [2] Stability: $\pm 3\%$ FS under EMC test environment.

# 10. Specifications and external dimensions

## 10.1.2 External dimensions of the detector

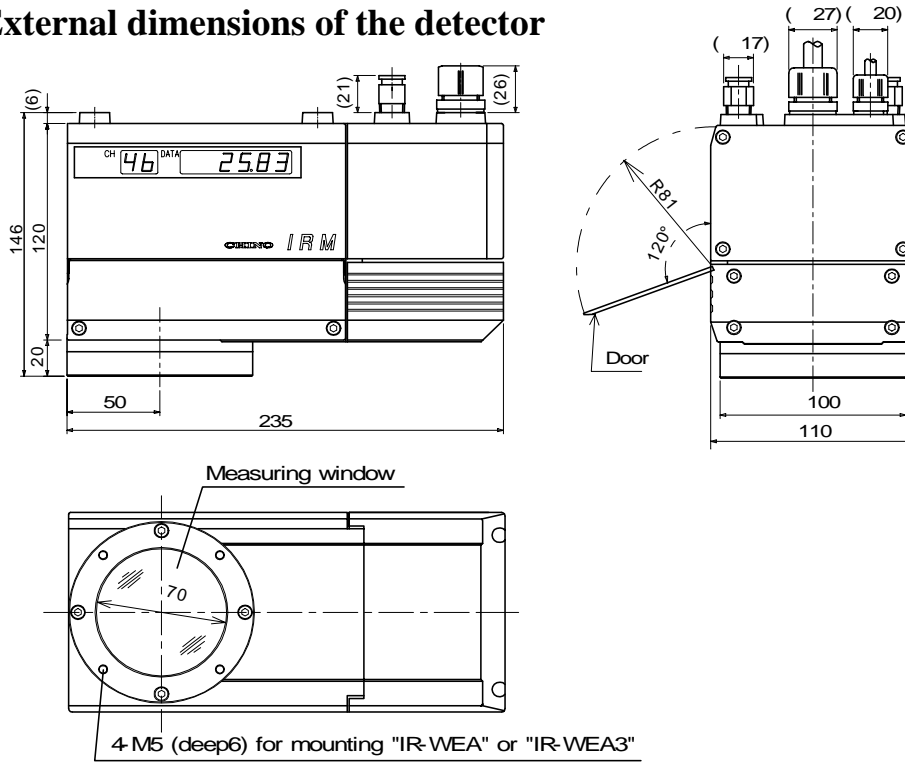

## 10.2 Power supply unit (conforming to CE): Model IR-WEP

Supplying 24VDC to the detector. It is attached to the detector as the accessories.

Item	Specification
Output voltage	24V DC
Output current	2.1A
Working temperature range	-10 to 50°C
Power supply	100 to 240V/AC 47 to 450Hz
Allowable voltage fluctuation	+10% to (-) 15% of rated value
Power consumption	Maximum about 160VA
Case	Horizontal mounting holder, flange holder
Mounting	Wall mounting type (DIN rail)
Weight	About 380g

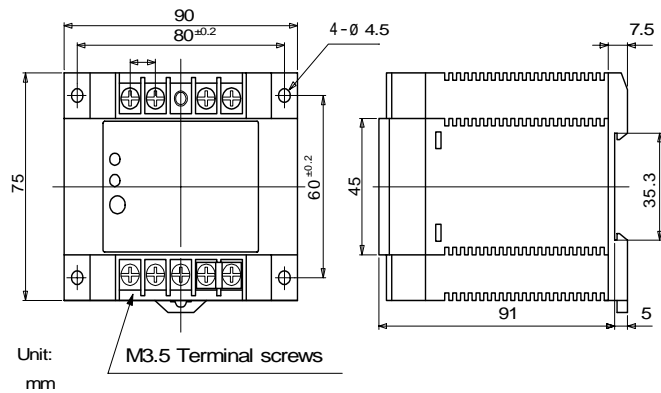

## 10.3 Connection cable: Model IR-WERT

It is the exclusive cable used for the connection between the detector unit and the setting display unit/power supply unit.

Item	Specification
Structure	4-core cab tire cable (With double shield)
External diameter	φ10mm
Length	Maximum 200m
Connection	Both end tips

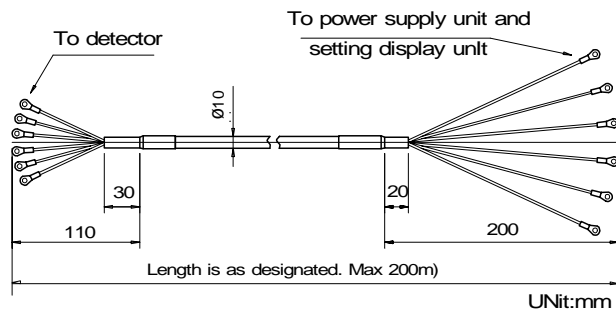

# 10. Specifications and external dimensions

## 10.4 Air purge hood: Model IR-WEA for Model IR-M1700

This is used for shielding the external light and purging the measuring window and measuring optical path by means of air. The output checker plate can be mounted at the tip of the hood.

Item	Specification
Purge air	50 to 200NI/min Pressure Max. 200kPa (Use an instrumentation air excluding oil, dust, and foreign substances.)

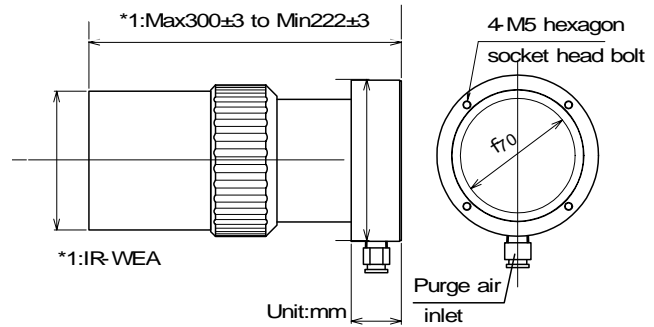

## 10.5 Output checker plate: Model IR-WEB for Model IR-M1700

This is used for checking the detector output at site by mounting it at the tip of the air purge hood.

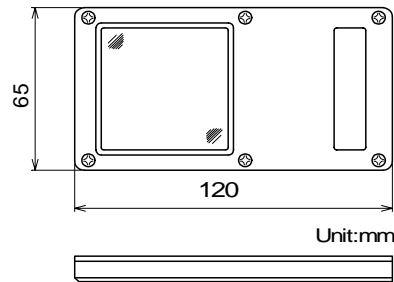

## 10.6 Water cooling plate: IR-WEW

This is used for mounting the detector to the high temperature atmosphere over 45°C. Use one sheet or 2 sheets according to situation. However, 2 sheets using only Model IR-M17□□□N.

Item	Specification
Environment temperature	One using: 0 to 60 °C Two using: 0 to 60 °C
Cooling water	Flow: 0.5 to 1NI/min Pressure: Max. 200kPa Temperature: Less than 30 °C at the exit side.
Case	SUS304
Weight	About 0.8Kg

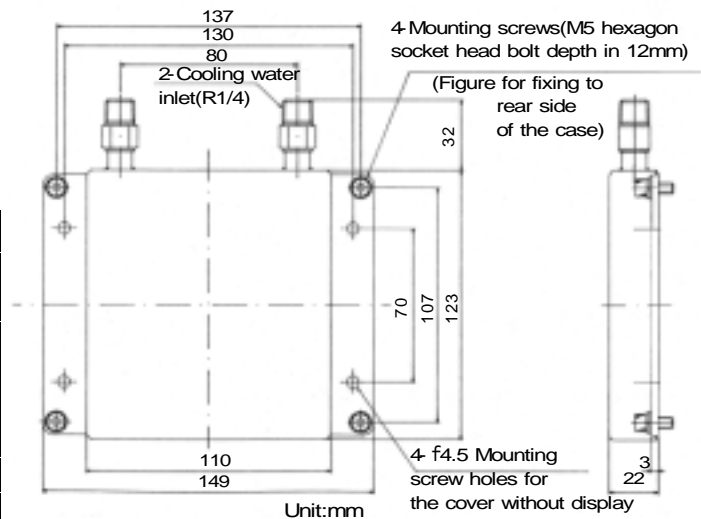

# 10. Specifications and external dimensions

## 10.7 Mounting adapter: IR-WED

This is used for replacing to IR-M1700 from IR-M1700 that attached to before it uses.

There is not the change of an attachment place.

Item	Specification
Material	Aluminum
Weight	About 0.8Kg

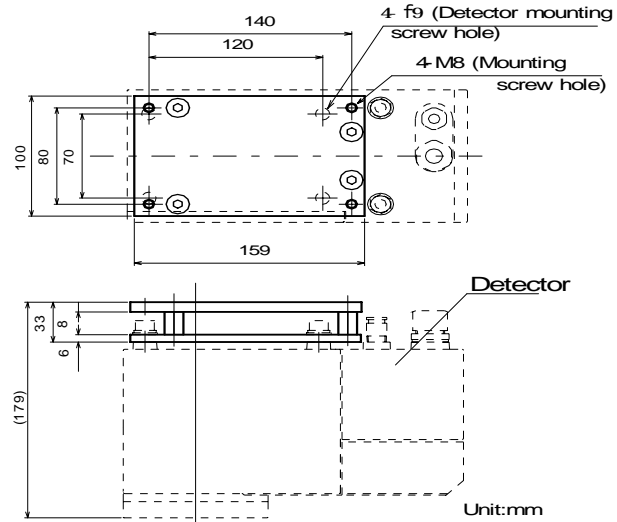

## 10.8 Air cooling box: IR-WEX

This is used for cooling the detector, for dustproof of the detector by air purging. (The detector is stored to IR-WEX.)

Item	Specification
Environment temperature	0 to 55 °C
Cooling air	Flow: 100 to 500NI/min
Material	Case department: SUS304 Mounting fittings department
Weight	About 14Kg

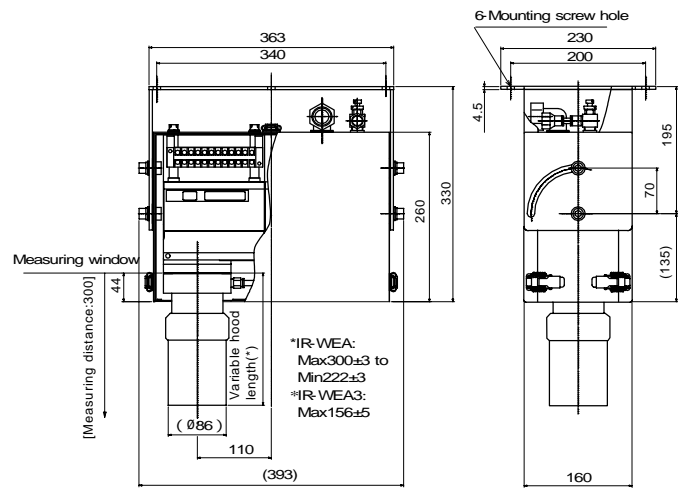

## 10.9 Relaying box: IR-WEE1, IR-WEE2

This is used for connecting the plural detectors as relay terminals.

(The power supply unit: IR-WEP is stored in IR-WEE.)

Item	IR-WEE1	IR-WEE2
Environment temperature	0 to 50 °C	0 to 50 °C
Material	Steel	SUS304
Color	5Y7/1	
Weight	About 4Kg (The power supply unit is included)	About 14Kg (The power supply unit is included)

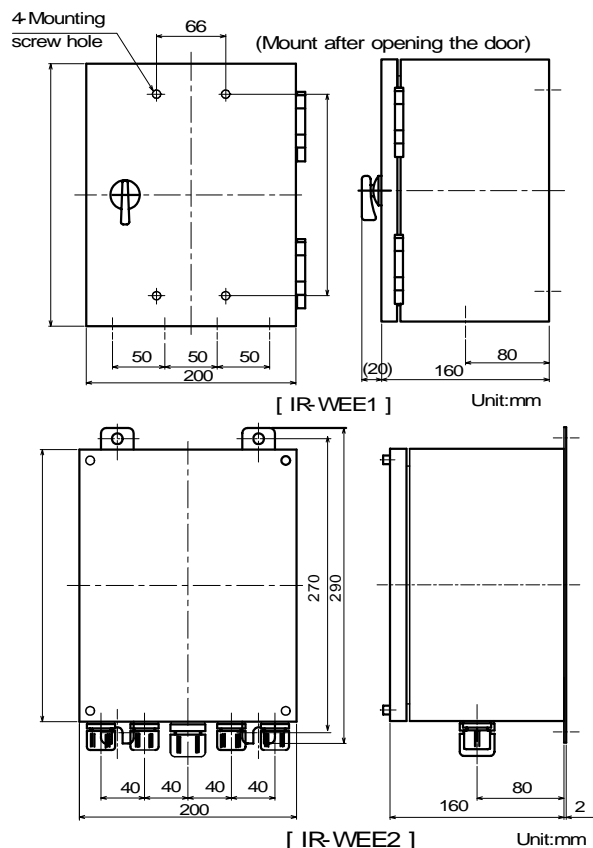

# CHINO

---

## CHINO CORPORATION

32-8, KUMANO-CHO, ITABASHI-KU, TOKYO 173-8632

Telephone: +81-3-3956-2171

Facsimile: +81-3-3956-0915

E-mail: [inter@chino.co.jp](mailto:inter@chino.co.jp)

Web site <http://www.chino.co.jp/>

---

